HYDRIM L110w G4

INSTRUMENT WASHER

- Service Manual



HYDRIM L110w G4 Service Manual 96-113788 Rev. 1.0 Copyright 2013 SciCan Ltd. All rights reserved

SciCan

| Your Infection Control Specialist™

Contents

1. Introduction	4	3. Diagnostics and Troubleshooting...	30
1.1 Overview.....	4	3.1 Using the service menu.....	30
1.2 Unit at a glance.....	5	3.2 Using the setup menu.....	31
Front and rear of unit.....	5	3.3 Using the user menu.....	32
Left and right of unit.....	6	3.4 Using software tools for diagnostics.....	33
1.3 Specifications.....	7	Debug Screen.....	33
1.4 Safety information.....	8	I/O status screen.....	34
Safe operation.....	8	3.5 Troubleshooting cycle faults.....	35
Safe servicing.....	8		
1.5 Tools and hardware.....	9	4. Removing and Replacing Panels ...	38
1.6 Disconnecting the unit.....	10	4.1 Removing and reinstalling	
1.7 Shipping instructions.....	11	the top panel.....	39
1.8 Installation.....	12	4.2 Removing and reinstalling	
1.9 Setting water softener.....	14	the side and rear panels.....	39
1.10 Setting the language.....	15		
1.11 Setting the country.....	15	5. Front Components	40
1.12 Setting the time.....	15	5.1 Removing and reinstalling	
1.13 Setting the date.....	16	the kickplate.....	41
1.14 Assigning the unit identifier number....	16	5.2 Opening the door with	
1.15 Adjusting the screensaver delay.....	17	the manual door release.....	41
1.16 Adjusting temperature display.....	17	5.3 Removing and reinstalling	
1.17 Turning the button sound ON or OFF..	17	the sump temperature sensor.....	42
1.18 Adjusting the button beep volume.....	17	5.4 Removing and reinstalling	
1.19 Adjusting the salt regeneration.....	18	the chemical dosing valve.....	43
1.20 Adjusting the screen contrast.....	18	5.5 Removing and reinstalling	
1.21 Changing the touchscreen		the chemical reservoirs.....	44
display themes.....	18		
1.22 Creating a user name.....	19	6. Door Components	45
1.23 Creating a user PIN.....	19	6.1 Removing and reinstalling	
1.24 Setting up process enforced usage....	20	the chamber seal.....	46
1.25 Connecting to a network.....	20	6.2 Removing and reinstalling	
1.26 Connecting to a wireless network.....	21	the lower door seal.....	47
		6.3 Removing and reinstalling the door.....	48
		6.4 Removing and reinstalling	
		the lower door D-seal.....	49
		6.5 Removing and reinstalling	
		the door latch.....	49
		6.6 Removing and reinstalling	
		the door springs.....	50
2. Routine Procedures			
and Maintenance	22		
2.1 Replacing the cleaning solution.....	22		
2.2 Refilling the water softener.....	23		
2.3 Filter and wash arm maintenance.....	24		
2.4 Cleaning the chamber.....	25		
2.5 Draining the unit for service or shipping	25		
2.6 Upgrading the firmware and themes ..	25		
2.6.1 Using a USB drive with the software			
loaded onto it.....	26		
2.6.2 Upgrading another HYDRIM G4 unit			
with the same USB drive.....	26		
2.7 Using the HYDRIM remote access function	29		
2.8 Annual service requirements.....	28		

Contents

7. Right Side Components	51	9. Rear Components	64
7.1 Removing and reinstalling the LCD touchscreen and LCD controller	52	9.1 Removing and replacing the Ethernet and RS232 ports.....	65
7.2 Removing and reinstalling the I/O board	54	9.2 Removing and reinstalling the air chamber pressure switch.....	65
7.3 Removing and reinstalling the power supply.....	55	9.3 Removing and reinstalling the water softener system.....	66
7.4 Removing and reinstalling the dosing pump	56	9.4 Removing and reinstalling the air break.....	67
7.5 Removing and reinstalling the chamber level/overflow switch.....	57	9.5 Removing and reinstalling the water inlet valves.....	68
7.6 Removing and reinstalling the drain pump and exhaust assembly.....	58	9.6 Removing and reinstalling the fuses and fuse holders.....	69
7.7 Removing and reinstalling the dryer motor.....	59	9.7 Removing and reinstalling the AC power inlet / EMI Filter	69
7.8 Removing and reinstalling the power switch	60	10. Spare Parts & Accessories	70
7.9 Removing and reinstalling the USB port.....	60	11. Appendices	73
8. Left Side Components	61	Appendix A HYDR/IM L110w G4 Electrical Schematic.....	73
8.1 Removing and reinstalling the sump water heater	62	Appendix B HYDR/IM L110w G4 Flow Diagram	74
8.2 Removing and reinstalling the recirculation pump.....	63		

HYDR/IM and STAT/IM are registered trademarks of SciCan Ltd. BRAVO, HIP, and SysTM are trademarks of SciCan Ltd. All other trademarks referred to in this manual are the property of their respective owners.

For all service and repair inquiries:

In Canada 1-800-870-7777
United States: 1-800-572-1211
Germany: +49 (0)7561 98343 - 0
International: (416) 446-4500
Email: techservice.ca@scican.com

Manufactured by:

SciCan Ltd.

1440 Don Mills Road,
Toronto ON M3B 3P9
CANADA

Phone: (416) 445-1600
Fax: (416) 445-2727
Toll free: 1-800-667-7733



EU Representative

SciCan GmbH
Wangener Strasse 78
88299 Leutkirch GERMANY
Tel.: +49 (0)7561 98343 - 0
Fax: +49 (0)7561 98343 - 699

SciCan Inc.

701 Technology Drive
Canonsburg, PA 15317 USA
Phone: +1 724 820 1600
Fax: +1 724 820 1479
Toll free: 1-800-572-1211

SciCan Medtech

Alpenstrasse 16
CH-6300 ZUG SWITZERLAND
Phone: +41 (0) 41 727 7027
Fax: +41 (0) 41 727 7029

1. Introduction

1.1 Overview

This guide provides instructions for the servicing and repair of the HYDRIM® L110w G4 Instrument Washer. Every attempt has been made to provide accurate, detailed instructions.

HYDRIM L110w G4 instrument washer cycle description chart

Cycle	Prewash	Wash	Rinse	Dry	Total Time** w/o Drying	Water Consumption
P0 – Machine Cleaning Cycle No initial draining.	<30°C/86°F (cold) 3 minutes	N/A	<30°C (cold) 2 minutes	N/A	7 minutes	16 L 4.23 Gal
P1 – Rinse and Hold Cycle* Use to prevent soil from drying on instruments when they will not be washed within one hour.	<30°C/86°F (cold) 3 minutes	N/A	60°C/140°F 1 minute	N/A	9 minutes	16 L 4.23 Gal
P2 – Regular Cycle Use for moderately soiled loose instruments.	N/A	50°C/122°F 5-15 minutes (default 5 minutes)	60°C/140°F*** 1-10 minutes (default 1 minute)	1-25 minutes (default 10 minutes)	25 minutes	24L 6.34 Gal
P3 – Heavy Duty Cycle Use for heavily soiled instruments and cassettes.	<30°C/86°F (cold) 3 minutes	50°C/122°F 5-15 minutes (default 9 minutes)	60°C/140°F 1 minute	1-25 minutes (default 10 minutes)	34 minutes	32L 8.45 Gal

* This is not a wash cycle. Always run a wash cycle following the rinse & hold cycle.

** Cycle times depend on the temperature and pressure of incoming water.

*** Rinse times are adjustable up to 10 minutes by an authorized technician.

1.2 HYDRIM Unit at a glance - front and rear

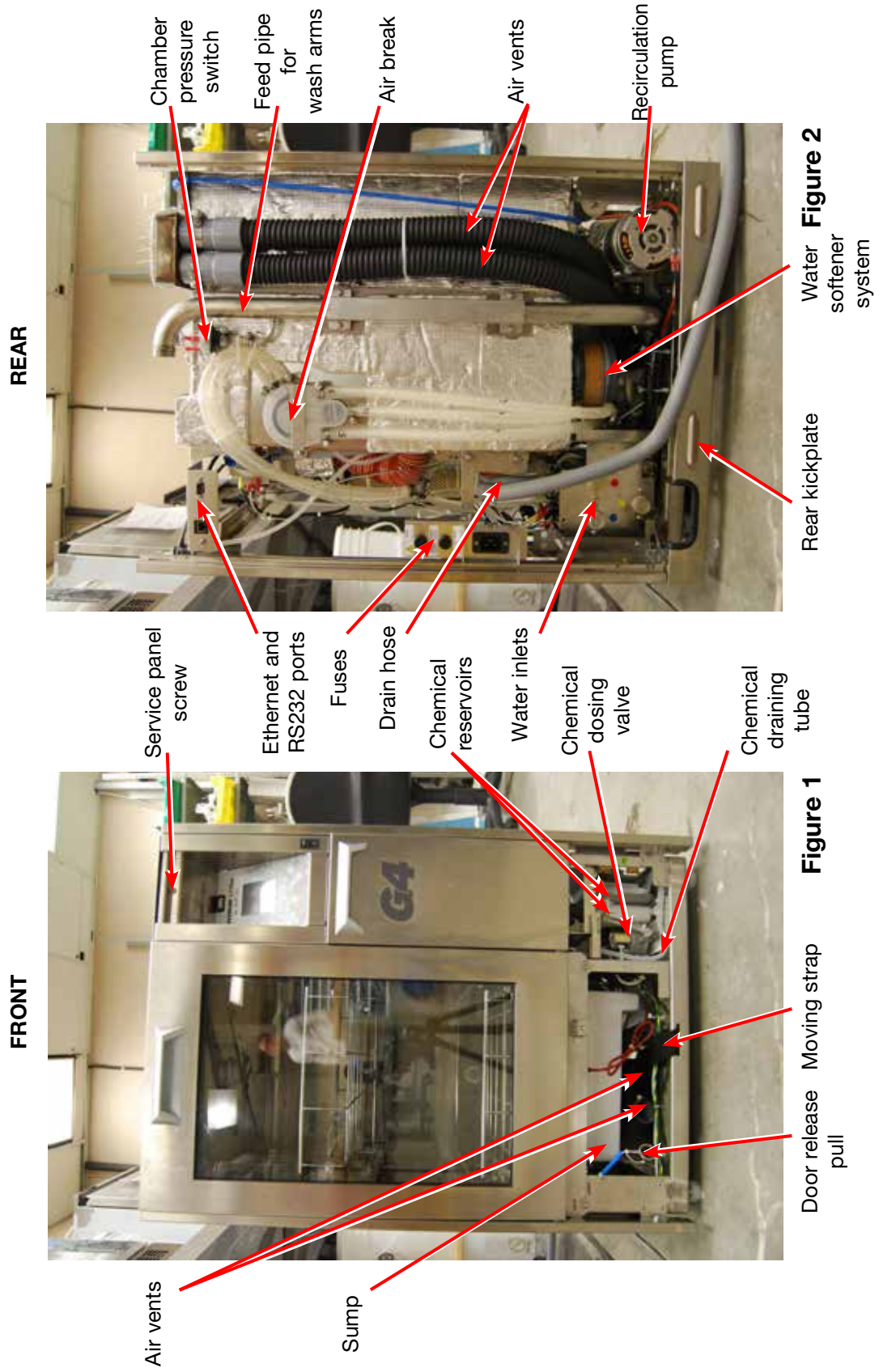

1. Introduction

1.2 HYDRIM Unit at a glance - left and right

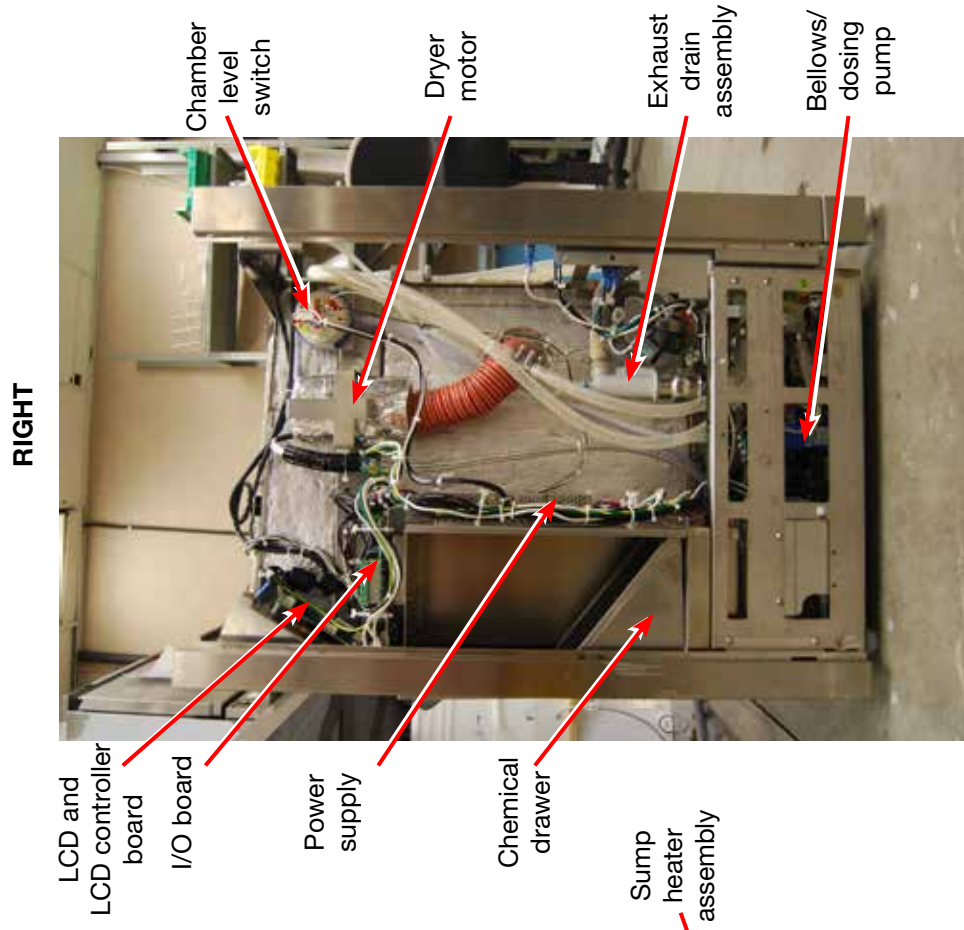

Figure 4

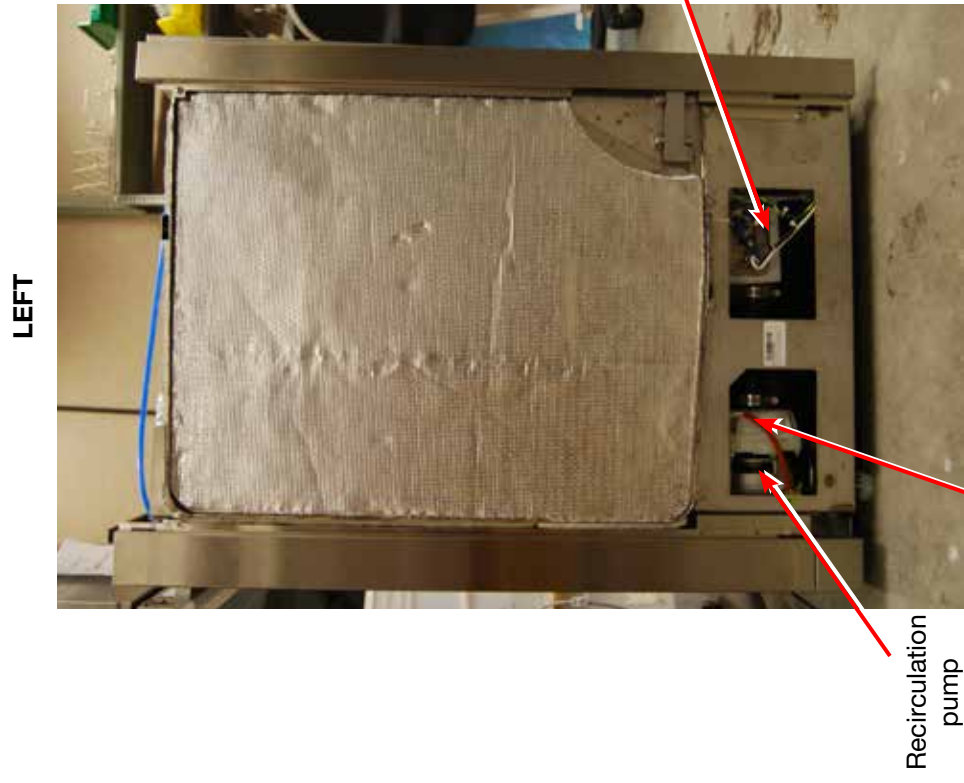

Figure 3

1. Introduction

1.3 Specifications

Machine dimensions:	Height, freestanding:	85 cm	33.5"
	Width:	60 cm	23.75"
	Depth:	60 cm	23.75"
	Depth with door open:	120 cm	47"
Weight :		80 kg	176 lbs
Maximum Running noise:		78 dB(A)	
Hot and cold water connections		G 3/4"	
Inlet water pressure:		1-10 bar	
Incoming hot water temperature:		50-70°C	22-158°F
Drain:		3/4"	
Water softener:		1 kg / 2.2 lbs salt capacity	
Filling System:		5.5L / 1.5 gallon safety maximum	
Drying system:		Heater 1 kW	
Electrical connection:		208-240VAC ±10%, single-phase, 60 Hz, 15A	
Protection class:		Class I	
Equipment pollution degree:		Pollution degree 2	
Equipment installation category:		Installation category II	
Maximum relative humidity:		60% for temp up to 31°C/88°F 50% for temp up to 40°C/104°F	
Operating temperature range:		5°C to 40°C	41° to 104°F
Max. altitude:		2000 m	6,562 feet
Mains supply:		+ / -10% of nominal	
Fuses:		15A, 250V, Type F	

When ordering supplies, spare parts or requesting service, please ensure that the information contained on the serial number plate is available (Model number, serial number etc.).

The serial number plate is located at the bottom left on the rear panel of the HYDR/M L110w G4 unit. A small label is located on the left hand side of the chemical door.

1. Introduction

1.4 Safety information

The following symbols appear in the margins of this book.



A potential hazard to the operator.



A situation that may lead to a mechanical failure.



Important information

The following symbols appear on the unit:



Caution: Hot Surface and/or Hot Steam



Caution: Risk of electrical shock. Disconnect supply before servicing.



Caution: Refer to manual for details.



Safe operation

The following apply to both operators and service technicians:

- Exercise caution and seek assistance when lifting or carrying the unit.
- Cleaning solutions may irritate. Avoid contact with eyes, skin and mouth.
- Never lean on the open door. The unit may tip forward causing injury.
- Always turn the unit OFF before adding softener salt or solutions. Before performing routine maintenance or servicing the unit, turn the unit OFF and unplug the power cord from the power source.
- The operator should never remove the cover of the unit or insert objects through holes or openings in the cabinetry. Doing so may damage the unit and/or pose a hazard to the operator.
- If the unit is used in a manner other than that specified, the protection provided by the equipment may be impaired.



Safe servicing

- The HYDR/M L110w G4 Instrument Washer should only be installed and serviced by a qualified contractor as it is an Installation Category 2 device. The contractor should be experienced in installing equipment that requires electrical hook-up as well as plumbing.
- SciCan shall not be liable for incidental, special or consequential damages caused by any maintenance or services performed on the HYDR/M L110w G4 by a third party or for the use of equipment or parts manufactured by a third party, including lost profits, any commercial loss, economic loss, or loss arising from personal injury.
- All local, regional, state, and national regulations regarding the servicing of this class of device and safety requirements must be observed.

1. Introduction



When the cover and panels are removed:

- Hazardous voltages are accessible. Disconnect the power cord before removing the cover or any panels.
- Sharp metal edges are exposed. Be careful, and wear long sleeves and gloves.

Power main

- If the cover or panels are removed, a dielectric strength test (hi-pot) must be performed on the unit once the cover or panels are reinstalled.

Ground

- If the cover or panels are removed, a protective bonding impedance test (ground continuity) must be performed on the unit once the cover or panels are reinstalled.

Reporting

- It is vital for SciCan to learn of any problem in the field. This information will help SciCan solve the problem quickly and improve product reliability in new units.

Biological waste

- Waste water in the unit may contain biological contaminants. Use a mechanical means or absorbent material to siphon the contents from the sump. Wear disposable rubber gloves. Dispose of absorbent material according to biological waste disposal regulations.

1.5 Tools and hardware

Tools required for servicing include:

- Needle-nose pliers
- Screwdrivers Phillips 1 & 2
- Screwdriver slot
- Wire cutters
- Small slot screwdriver
- 8 mm Nut driver
- Allen key 3.0 mm
- Channel Locks
- Spring clamp pliers

Electrical Safety test equipment:

- Hi-Pot tester
- Ground continuity tester
- Static strap
- Static bags

1. Introduction

The unit contains the following types of hardware:

- Phillips pan head self-tapping metal screws
- Phillips pan head stainless steel machine screws
- Hex socket pan head stainless steel machine screws
- Spring clamps
- Band / Gear clamps
- Cable ties

1.6 Disconnecting the unit

To disconnect the unit, follow these steps:

1. Turn the unit off and disconnect it from the power supply.
2. Turn off the water supply.
3. Disconnect the drain and water intake hoses.
4. Remove the screw at the center of the kickplate and remove the kickplate to access the moving strap.
5. Pull the unit out using the moving strap and carefully withdraw the hoses at the same time.

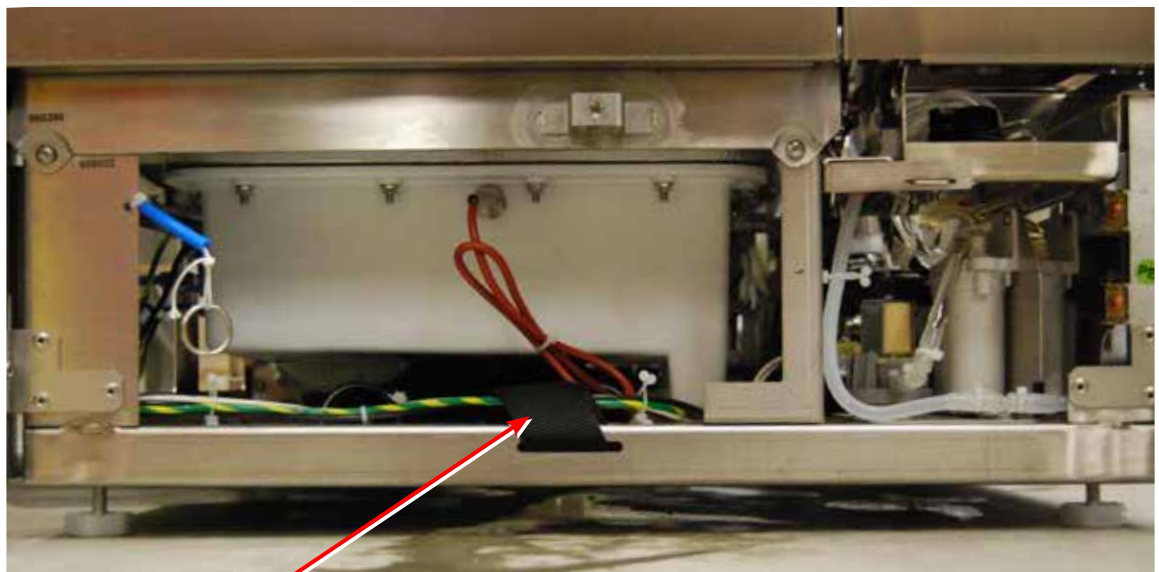

Moving strap

Figure 5

1. Introduction

1.7 Shipping instructions

The unit should be serviced on site. If it is necessary to send the unit back to the dealer, follow these instructions:

- Run the 'Prepare for Shipping' cycle in the setup menu to remove most of the water from the system before shipping the unit.
- Waste water in the unit may contain biological contaminants. Use a mechanical means or absorbent material to siphon the contents from the sump. Wear disposable rubber gloves. Dispose of absorbent material according to biological waste disposal regulations.
- Disconnect and remove the cleaning pouch container and then drain the dosing reservoir.
- Screw in the leveling legs.
- Specify upright, heated, and insured shipping.
- Ensure unit is returned on a pallet with at least two banding straps securing the box to the pallet. If original packaging is unavailable packaging can be ordered with part # 01-111667S.
- Shipping outside of these conditions can affect warranty.

1. Introduction

1.8 Installation

IMPORTANT INFORMATION



Pre-Installation

The machine must be installed and leveled correctly for the unit to function as described. All electrical work must be carried out by a qualified electrician and in compliance with all local and national electrical codes.

Voltage: 208-240V
Frequency: 60 Hz
Rated load: 2.5 kW
Circuit breaker: 15A

- The outlet needs to be accessible after the unit is installed.
- The appliance must be correctly grounded! The manufacturer cannot be held responsible for damage or injury caused by incorrect or missing grounding.
- The HYDRIM unit is heavy (80 Kg/176 lbs). Exercise caution and obtain assistance when lifting unit.
- If you need to extend the water inlet and drain hoses, ensure that you use commercial grade plumbing hose. The maximum length of the drain hose is 3.3 m /11'

Installation instructions

Installation should only be undertaken by a manufacturer approved technician. The use of an unapproved installer may invalidate the warranty. A separate pre-installation checklist should have been supplied to the user by the dealer (SD-429). Please review this prior to approving installation, download at mySciCan.com.

If the HYDRIM L110w G4 is installed in a sterilization center, the manufacturer of the sterilization center should allow enough space at the top, back and both sides of the unit to facilitate installation, leveling, and service access to the unit. During installation, all consumables should have been added to the machine as appropriate. It is important to check that this has been undertaken before starting the machine.

The HYDRIM L110w G4 should only be installed and service by a qualified SciCan contractor, as it is an installation Category 2 device. The contractor should be experienced in installing equipment that requires electrical hook-up as well as plumbing.

The machine must be installed and leveled (see leveling instructions on next page) correctly for the unit to function as described. All electrical work must be carried out by a qualified electrician and in compliance with all local and national electrical codes.

1. Introduction

Leveling the HYDRIM

The unit is standing on three supports: rollers (wheels) at the back and two legs at the front.

1. Remove the kickplate. Push the HYDRIM into place while lifting the strap at the front to allow the unit to roll on the rollers.
2. Adjust the front legs as required until the HYDRIM is level. Access the legs from inside the unit.
3. The rear two legs are used only if the floor is uneven or cannot provide support to the rollers.

Electrical connection

This appliance must be correctly grounded! The manufacturer cannot be held responsible for damage or injury caused by incorrect or missing grounding. Before making any connections check that the voltage shown on the serial number label corresponds to your power supply. The machine is supplied as standard for connection to 208-240V 60 Hz single-phase power supply and is fitted with a power supply cord 1.8m/6ft long, with a 6-15 NEMA plug. It should be connected to the main power supply according to the information below.

Voltage: 208-240V

Frequency: 60 Hz

Rated load: 2.5 kW

Circuit breaker: 15A

Connection to the water supply

The unit must be connected to the water supply in accordance with all local and national plumbing codes. SciCan recommends a hard plumbing installation within 1.5m/5ft. of the unit. If additional distance is necessary, commercial grade plumbing hose must be used to minimize leaks. Connect inlet hoses to hot and cold water taps using the hoses connected to the unit and in accordance with the installation instructions.

Water Pressure: 1-10 bar/14.5-145 psi

Water Temperature: Cold water less than 30°C/86°F

Hot water up to 60°C/140°F

Drainage

The unit is supplied with a 1.5m/5ft flexible drain hose with a 2cm/3/4" barb inlet. The hose should not be shortened or attached to any fittings that would cause a reduction in water flow. The drain system is equipped with a non-return valve that prevents dirty water from flowing back into the unit.

The drain hose should not be further than 1.5m/5ft. from a hard plumbing drain. If this is not possible, then commercial grade plumbing hose must be used to minimize leaks.

The hose can be attached to an existing drain through the use of a 3.5cm/1½" or larger stand pipe/ P-trap combination. Alternatively, the hose can be connected directly to the existing drain lines, provided the fittings or adapters used do not reduce the water flow. The drain hose should not exceed 3.3m/11ft in length, or be attached to the main drain at a point higher than 35cm/14" above the floor.

1. Introduction

1.9 Setting the water softener

The HYDRIM L110w G4 is equipped with a built-in water softening system that must be adjusted according to the local water hardness. To read local water hardness, proceed as follows:

1. The water test kit included with your HYDRIM contains three water hardness test strips in bags. Take a water sample from the location where the machine will be installed.
2. Open one of the bags, remove the test strip and dip it into the water.
3. Compare the color of the strip with the chart on the back of the bag Determine the water hardness according to the chart on the water test kit envelope.
4. Power the unit on and select the Settings key from the main menu.
5. Go to the Setup Menu, Cycle Settings, and select “Set Regeneration”.
7. Using the up and down arrows, set the water softener regeneration level according to the water hardness table in this section. If your water hardness falls between two settings, select the higher setting.
8. Unscrew the water softener container lid from the bottom left of the chamber and pour 1 litre (1 quart) of water into the water softener container.
9. Add 1 kg (22 lbs) of water softening salt to the water softener container, using the supplied funnel to prevent any salt from spilling into the chamber, and close by screwing the lid **tightly** back into place. An improper seal can lead to corrosion.

Water Hardness Conversion and salt regeneration levels

	°dH	US GPG	PPM (mg CaCO ₃ / Litre)	Regen.
Typically No Treatment Necessary (values from 18-143)	1	1.0	18	1
	2	2.1	36	
	3	3.1	54	
	4	4.2	71	
	5	5.2	89	
	5.6	5.8	100	
	2	6	6.3	107
		6.2	6.4	110
May Require External Treatment (values from 150-535)	7	7.3	125	3
	8	8.3	143	
	8.4	8.8	150	
	9	9.4	161	
	10	10.4	178	
	10.1	10.5	180	
	11	11.5	196	
	11.2	11.7	200	
	11.8	12.3	210	4
	12	12.5	214	
	13	13.6	232	
	14	14.6	250*	
	15	15.6	268	5
	16	16.7	286	
	16.8	17.5	300	
	17	17.7	303	
	18	18.8	321	6
	19	19.8	339	
	19.6	20.5	350	
	20	20.9	357	
	20.2	21.0	360	
	21	21.9	375	7
22	22.9	393		
22.4	23.4	400		
23	24.0	411		
24	25.0	428		
25	26.1	446		
25.2	26.3	450		
26	27.1	464		
27	28.2	482	8	
28	29.2	500		
28.6	29.8	510		
29	30.2	518		
30	31.3	535		
External Treatment Required (values > 535)	≥30.3	≥31.6	≥540	Additional Water Treatment Required

*Please note: The water test strip is only accurate up to 250 ppm. If the reading on the test strip exceeds 250 ppm and/or if the location in which the HYDRIM is installed has known water quality problems, having a more detailed and accurate water test done by a test lab is strongly recommended.

1. Introduction



IMPORTANT: The HYDRIM's water softening system reduces the water hardness by taking out Calcium Carbonate. If the water testing results show that the water hardness is outside the unit's range of adjustment, or if other dissolved solids in the water cause stains or deposits on the instruments or chamber, an external water treatment system may be required.

1.10 Setting the language

The messages displayed by your HYDRIM can be presented in a number of different languages. To change the current language, follow these steps:



2. Scroll to **Language Selection** and select.

3. From the LANGUAGE screen, press   to scroll through the list of languages. When you have found the desired language, press  to save your selection and return to the Setup menu.

1.11 Setting the country



2. Scroll to **Country** and select.

3. Using the keypad, type the name of the country and press **EN** to select. Press  to save and return to the Setup menu.

1.12 Setting the time











2. Scroll to **Date/Time** and select Time Setup.









3. From the TIME screen, use the keypad to set the time. Press **EN** to save and  to return to the Setup menu.

1. Introduction







NOTE: If the HYDR/M is connected to a network, it is important to also enter the correct Time Zone. Enter the Time submenu, select Time Zone and scroll and select your local time zone.

4. To change your unit to display 12-hour time format (24-hour time format is the default setting), go to the Setup menu and use   to scroll to TIME 12/24, select it and toggle to 12. Press  to save and return to the Setup menu.
5. To activate daylight savings time (DST), go to the Setup menu and use   to scroll to DST ON/OFF and select. Use   to toggle DST ON or OFF and press the  to save and return to the Setup menu.

1.13 Setting the date

1.     
2. Scroll to and select Date Setup.
3. From the DATE screen, use the keypad to set the date. Press to save and  to return to the Setup menu.
4. To change the format in which the date appears, return to the Setup menu and use   to scroll to DATE FORMAT. Select it, and follow the prompts to have the date displayed in the desired format. Press  to save and return to the Setup menu.

1.14 Assigning unit identifier number

1.     
2. Scroll to and select.
3. Using the keypad, select a maximum of 3 digits to be used as the unit's identifier number. Press to save and  to return to the Setup menu.



1. Introduction

1.15 Adjusting the screensaver delay

To change the length of time before the screensaver is activated, follow these steps:





2. Scroll to **Screensaver** and select.

3. Use   to scroll through your time options. When you have found the amount of time you require, press it. Press  to save and return to the Setup menu.

1.16 Adjusting the temperature display



2. Scroll to **Temperature C/F** and select.

3. Use   to choose between having information displayed in degrees Celsius or Fahrenheit. Press  to save and return to the Setup menu.

1.17 Turning the button sound ON or OFF



The HYDRIM is preset to beep when a button is pressed. If you would like to turn the button sound off, follow these steps:



NOTE: Turning OFF the button sound does NOT turn off other alarms and cycle notification beeps.



2. Scroll to **Beep ON/OFF** and select.



3. Use   to scroll through your ON or OFF options and select it by pressing it. Press  to save and move back to the Setup menu.

1.18 Adjusting the button beep volume

If you would like to adjust the beep volume, follow these steps:



2. Scroll to **Beep Volume** and select.

3. Use   to scroll through the volume settings. Select the one you want by pressing it. Press  to save and move back to the Setup menu.



1. Introduction

1.19 Adjusting the salt regeneration

Salt regeneration should be set according to the local water hardness. See section 1.8 Setting the water softener for instructions on determining correct settings. To set salt regeneration, follow these steps:



2. Scroll to **Set Regeneration** and select.



3. Use   to change the value. The default setting is 1. Press  to save and return to the Setup menu.

1.20 Adjusting the screen contrast

The touchscreen is calibrated for the lighting condition of most sterilization centers. Should you need to adjust the contrast for your office, follow these steps:



2. Scroll to **LCD Contrast** and select.

3. Use   to scroll through your contrast options. When you have found the contrast you require, press it. Press  to save and return to the Setup menu.

1.21 Changing the touchscreen display themes

The touchscreen themes (i.e. icons and background colours) can be changed to one of the preset options. To change themes follow these steps:





2. Scroll to **Theme** and select.

3. In the **Change Theme** screen, use   to scroll through your available options. As you scroll, each theme will display on the touchscreen. Press  to select your theme and return to the Setup menu.

1. Introduction

1.22 Creating a User Name





Up to four unique User Names can be created. To assign a User Name follow these steps:

1.  →  → 
2. Scroll to **User** and select.
3. To assign a user name, select **User Name** and use the alphabetic keypad to enter a name (up to 12 characters) and press **EN** to save.



1.23 Creating a User PIN

From the User PIN screen, you can assign up to four PINs. To assign a PIN, follow these steps:

1.  →  → 
2. Scroll to **User** and select.
3. To assign a user PIN, select **User PIN** and use the numeric keypad to enter a number (up to 4 digits) and select **EN** to save and  to move to the confirmation screen.









5. If all of the information presented in the confirmation screen is correct, press OK to be returned to the User PIN screen. To make a correction, select the User PIN you want to change and repeat the process described above.

1. Introduction

1.24 Setting up process enforced usage

When process enforced usage is activated, users are required to enter a PIN at the end of a cycle. For process enforced usage to function, User IDs and PINs must first be assigned. To set up User ID and PINs, refer to sections 1.23 and 1.24 on creating a user name and PIN. To activate process enforced usage, follow these steps:

1.  →  → 
2. Scroll to **Process Enforced** and select.
3. Use   to toggle process enforced function ON or OFF. Press  to save your selection and return to the Setup menu.



NOTE: Any user can stop a cycle even with process enforced usage ON. However, the cycle data will record that an unauthorized user has stopped the cycle.



1.25 Connecting to a network

The HYDR/M L110w G4 has a 10/100Base-T Ethernet port located at the back of the unit. To connect your HYDR/M to a network using a router, follow these steps:

1. Connect your network cable to the Ethernet port at the back of the unit. If your office uses a router, the router should automatically assign the unit an IP address. A red X on the network icon means the unit is not connected. A yellow check mark means the unit has an IP address but is not connected to the Internet and cannot send emails. A green check mark means the Internet connection is set up properly and the unit can send out emails.



NOTE: In some circumstances, where you do not have a router, for example when using Windows Network Sharing, you may have to assign a dedicated or 'static' IP address. To assign a static IP address, contact your local network administrator.

2. From the main screen, press the Network icon. The Network screen displays information about your HYDR/M's connectivity, including its IP address.



1. Introduction

3. Type the IP address displayed on the touchscreen into the browser of any web enabled device to access your unit's web portal. When the Network icon is active (for example when sending email) it will turn green.

NOTE: Use QR code if connecting to a mobile device.

NOTE: Connection time will vary depending on your network speed, and making an initial connection can take longer.



1.26 Connecting to a wireless network

The HYDRIM can be configured for wireless use by connecting the Ethernet port to an external wireless bridge / access point. SciCan currently recommends the use of the D-Link® DAP-1522 Xtreme N® Duo Wireless Bridge. Contact your network administrator to learn more about setting up a wireless bridge.

2. Routine Procedures and Maintenance

2.1 Replacing the cleaning solution

To replace the cleaning solution, follow these steps:

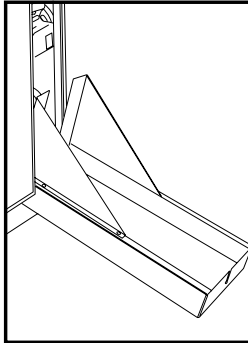

Open the cleaning solution drawer.

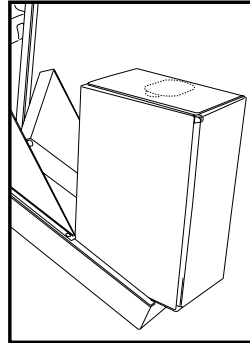

Put a new cleaning solution box into the drawer upside down.

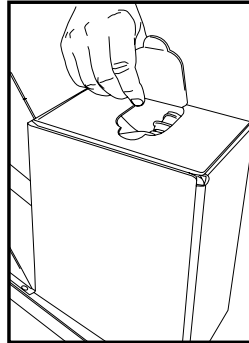

Tear open the tab.

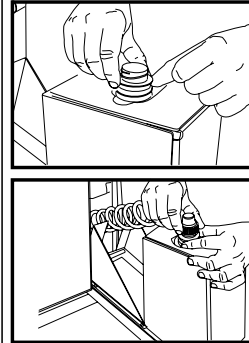

Pull out the spout and remove the protective cap. Connect the hose.

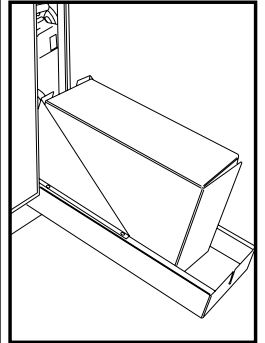

Place the box in the cleaning solution drawer and then close.

To prime the cleaning solution dosing pump, press the water softener/detergent icon on the main screen. In the water softener/detergent screen, press the red X next to “Detergent”. The unit will prime the dosing system and a green check mark will appear in place of the red X when it is ready for use.

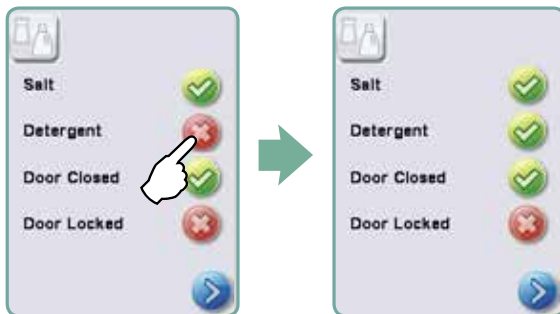

NOTE: The system can also be primed by simply starting a cycle and selecting “Detergent Replaced”, when prompted.

NOTE: A cycle will not start with the red X next to the “Detergent” indicator.

2. Routine Procedures and Maintenance

2.2 Refilling the water softener

If the water softener system is set to any value above 0, the message “Salt Level Low” will appear on the display. To add water softening salts, follow these steps:

1. Unscrew the salt container lid.
2. On first using the HYDRIM L110w G4, pour 1 liter (1 quart) of water into the salt container, or until it is full with water. **NOTE:** It is not necessary to add water during subsequent refills of the salt container.
3. Replace the salt container lid.



Figure 6

After the salt has been added to the unit, the softening salt indicator will initially show that more salt is needed. The indicator will turn off when the salt solution has become sufficiently concentrated

2.3 Filter and wash arm maintenance

Cleaning the chamber's coarse and fine filters

Inspect the coarse and fine filters in the bottom of the chamber daily for debris and clean if necessary. To clean the coarse filter, remove the filter, rinse under a tap and reinstall.

To clean the fine filter, remove the coarse filter, remove the two screws holding the fine filter and using a small screwdriver, gently pry the fine filter out. To replace, reinstall with the mesh side down.

Coarse filter – part # 01-113843S

Fine filter – part # 01-113844S



Figure 7

2. Routine Procedures and Maintenance

Removing and checking the wash arms

If you see that the wash arms are not turning easily, remove them. Both the upper and lower arms are thread mounted. Turn the mounting ring counter clockwise to remove. Rinse under a tap, clear obstructions from outlet holes and reinstall.

To remove the middle wash arm, twist the mounting ring one half turn counter clockwise to remove.

Lower, upper spray arm
– part # 01-109790S
Middle spray arm
– part # 01-111495S

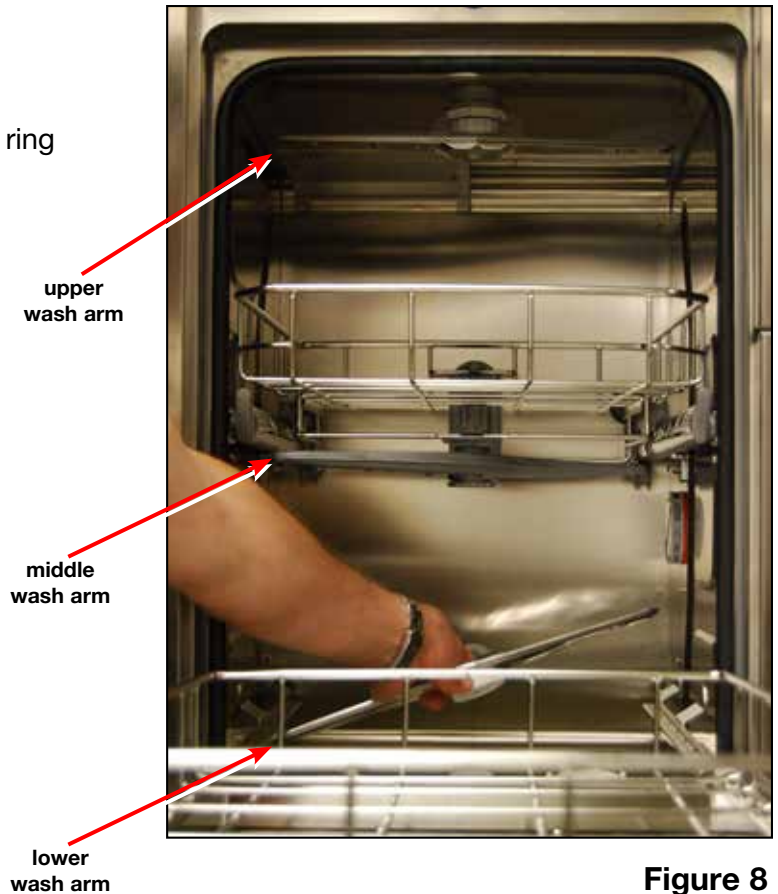

Figure 8

2. Routine Procedures and Maintenance

2.4 Cleaning the chamber

The HYDRIM L110w G4 chamber can be cleaned using the “Cleaning” program in the User menu. This cycle is used to periodically remove hardwater deposits from the chamber walls and racks. Pour 1 litre of vinegar into the chamber before starting the cycle. From the User menu, select “Cleaning” and a cleaning cycle, similar to a normal wash cycle, will run. The user will be prompted to clean the chamber every 25 cycles. Reminder frequency can be changed to 25, 50, or 75 cycles. To do this, enter the Technician menu.

2.5 Draining the unit for service or shipping

To drain the unit prior to shipping, or before tipping it onto its back for servicing, run the “Prepare for Shipping” cycle. Once complete, drain any water remaining in the air gap using the silicone tube located under the centre of the unit’s kickplate.

2.6 Upgrading the firmware and themes

NOTE: Instructional videos are available on <http://updates.scican.com>

NOTE: Upgrading the Interface Software can be done from a USB drive. The easiest and fastest method is to use a USB drive.

In order to manually upgrade the Interface and Themes software, please follow the steps below. This process will take approximately 30-35 minutes.

2.6.1 Using a USB drive with the software already loaded onto it

If using a USB drive with the software already loaded onto it, please start at step 3.

Using a blank USB drive

In order to use this method you must already have a zipped file with the appropriate files on your computer. The zipped file may have been emailed or provided to you.

1. Insert a new or blank (no files) USB drive into your computer.
2. Save the HYDRIM G4 software upgrade zip files (SH11MRXXX.zip) to your USB and extract the files contained in the zip files directly to the clean/blank USB drive.

Once the files are successfully unzipped to the USB drive, it is ready. Remove the drive from the computer. DO NOT INSERT the USB drive in to the Hydrim G4 yet.

3. Power the HYDRIM G4 unit OFF.
4. Insert the USB drive into the USB port located on the front, top, right corner of the unit.

2. Routine Procedures and Maintenance

5. Power the HYDRIM G4 unit ON.
6. Wait for approximately 10 minutes while the Interface software is being upgraded.

NOTE: During this process the screen will be blank.
The HYDRIM G4 will restart automatically to complete the upgrade.

DO NOT REMOVE THE USB DRIVE UNTIL THE END OF STEP 12

7. Once you see the home screen, browse to the Technician menu. When prompted enter the Technician password (7919 – password may differ from model to model) followed by EN to access the Technician options.
8. Scroll to the SW upgrade button. When prompted, enter password 5849 followed by EN.
9. Press Upgrade.
10. Wait up to 24 minutes.

NOTE: During this step, text will scroll in a box on the screen.

11. Once the process is complete, “(Done)” will be displayed in the box on the screen or unit automatically returns to the main screen
12. Remove the USB drive. Press the “back” arrow to return to the main screen. The HYDRIM G4 is ready to use.

To use the same USB drive to upgrade other HYDRIM G4 devices, you will need to reinitialize the USB drive. *Please follow the steps indicated in “To upgrade another HYDRIM G4 unit with the same USB drive”*

2.6.2 Upgrading another HYDRIM G4 unit with the same USB drive

To upgrade another HYDRIM G4 unit with the same USB drive

In order to use the same USB drive to upgrade another Hydrim G4 unit, the following steps must be followed.

1. Plug the USB drive into the computer.
2. Double click the FIRMWARE folder on the USB drive. (eg. Z:\FIRMWARE)
3. Copy the file `firmware.ini` file into the root directory of the USB drive. (eg. copy and paste the file `firmware.ini` from Z:\FIRMWARE\ to Z:\)
4. The USB drive is now ready to be reused to upgrade other Hydrim L110w G4 devices.

2. Routine Procedures and Maintenance

5. Power the HYDRIM G4 unit that you would like to upgrade next OFF.
6. Insert the USB drive into the USB port located on the front, top, right corner of the unit.
7. Power the HYDRIM G4 unit ON.
8. Wait for approximately 10 minutes while the Interface software is being upgraded.

NOTE: During this process the screen will be blank. The HYDRIM G4 will restart automatically to complete the upgrade.

DO NOT REMOVE THE USB DRIVE UNTIL THE END OF STEP 14

9. Once you see the home screen, browse to the Technician menu. When prompted enter the Technician password (7919 – password may differ from model to model) followed by EN to access the Technician options.
10. Scroll to the SW upgrade button. When prompted, enter password 5849 followed by EN.
11. Press Upgrade.
12. Wait up to 24 minutes.

NOTE: During this step, text will scroll in a box on the screen.

13. Once the process is complete, “(Done)” will be displayed in the box on the screen or unit automatically returns to the main screen.

14. Remove the USB drive. Press the “back” arrow to return to the main screen. The HYDRIM G4 is ready to use.

To use the same USB drive to upgrade other HYDRIM G4 devices, you will need to follow the above steps again, starting from step 1 of this section.

2.7 Using the HYDRIM remote access function

Users can allow offsite technicians to remotely access the LCD touchscreens and web portals of HYDRIM L110w G4 units connected to a network. This can be done either from within a network or from outside a network.

From within a network:

For local network remote access, the unit must be connected to a network. See Connecting to a network in section 1.25 of this manual for more details. From the unit’s web portal, proceed as follows:

From the TOOLS page, click on the LOCAL CONTROL tab.

Log in using the following credentials:

2. Routine Procedures and Maintenance

Username: scican

Password: s23can173

Click on the start button to start a local connection. It will open up a page that mirrors the HYDRIM unit's touchscreen so that it can be controlled remotely within a local network.

From outside a local network:

For remote access of a HYDRIM web portal or touchscreen from outside a local network, proceed as follows:

1. Someone onsite with the unit or from within the network must provide access to an outside user by generating a 'token' (or access code).
2. To generate a unique token using the web portal, go to the TOOLS page and click on the REMOTE ACCESS tab.
3. To generate a unique token using the unit's LCD touchscreen, go to the SETUP menu and scroll to REMOTE ACCESS and follow the prompts to enable remote access.
4. The technician attempting to access the unit from outside the network will need to go to the following URL: <http://updates.scican.com> and enter their registered email address, password, token and HYDRIM Serial Number (optional).
5. To create a new account to enable remote access for a HYDRIM, click on the CREATE NEW ACCOUNT link, complete the form, and click on the SUBMIT FORM link. The system will send a confirmation email. The account is ready to use.
6. Use the valid user name and password to enter Updates.scican.com and enter the token when prompted. This will bring you to the HYDRIM unit's web portal page.
7. Click on SETUP. A username and password prompt will appear. Log in using the following credentials:
 - Username: scican
 - Password: s23can173
8. Upon authentication, go to TOOLS and click on REMOTE ACCESS. Click on the start button to start a connection. It will open up a page that mirrors the HYDRIM unit's touchscreen so that it can be controlled remotely from outside its local network. Use your mouse to click and select touchscreen elements.

2.8 Annual Service Requirements

The HYDRIM L110w G4 is designed to be maintenance free; however, it is recommended that a SciCan-approved service technician perform an annual check.

The following checks are recommended in order to maintain optimum performance of the unit.

Annual service schedule

2. Routine Procedures and Maintenance

- Check integrity of incoming and outgoing services (power, water supply, drain)
- Check water supply in line filters and clean as appropriate
- Check general condition of machine
- Inspect and replace main chamber seal (only if required)
- Inspect and replace lower door seal (only if required)
- Check solution container connection for leaks
- Check salt level and replenish as required
- Check water hardness (test strips) and adjust salt regeneration settings if required.
- Inspect and clean sump filters (check sump for debris)
- Check wash arms for blockages and remove them for cleaning if required.
- Review error history
- Software upgrade (if necessary)
- Check individual component functionality. Go to the technician menu (enter access code 7919) and select 'Diagnostic Tools' then select 'Component Tests'. From here you can scroll through and check the functionality of the following components:
 - RO valve (if fitted)
 - Chamber heater
 - Door latch
 - Salt regeneration valve
 - Dosing pump
 - Dryer
 - Hot water valve
 - Cold water valve
 - Waste pump
 - Recirculation pump
- Check program selection
- Check dosing pump volume; dosing pump is pre-calibrated. Volume cannot be adjusted.
- Reset service cycle counter
- Clean machine
- Conduct electrical safety tests

Equipment and parts requirements for annual service

- Main chamber seal (Part number 01-113790S)
- Lower door seal (Part number 01-113789S)
- Service Manual (Part number 95-113788)
- Electrical safety test equipment
- Water hardness test strips (Part number 01-108305S)
- 100ml graduated measuring cylinder

3. Diagnostics and Troubleshooting

3.1 Using the service menu

To access the service menu, select the image of the technician and enter the service code 7919 on the keypad.

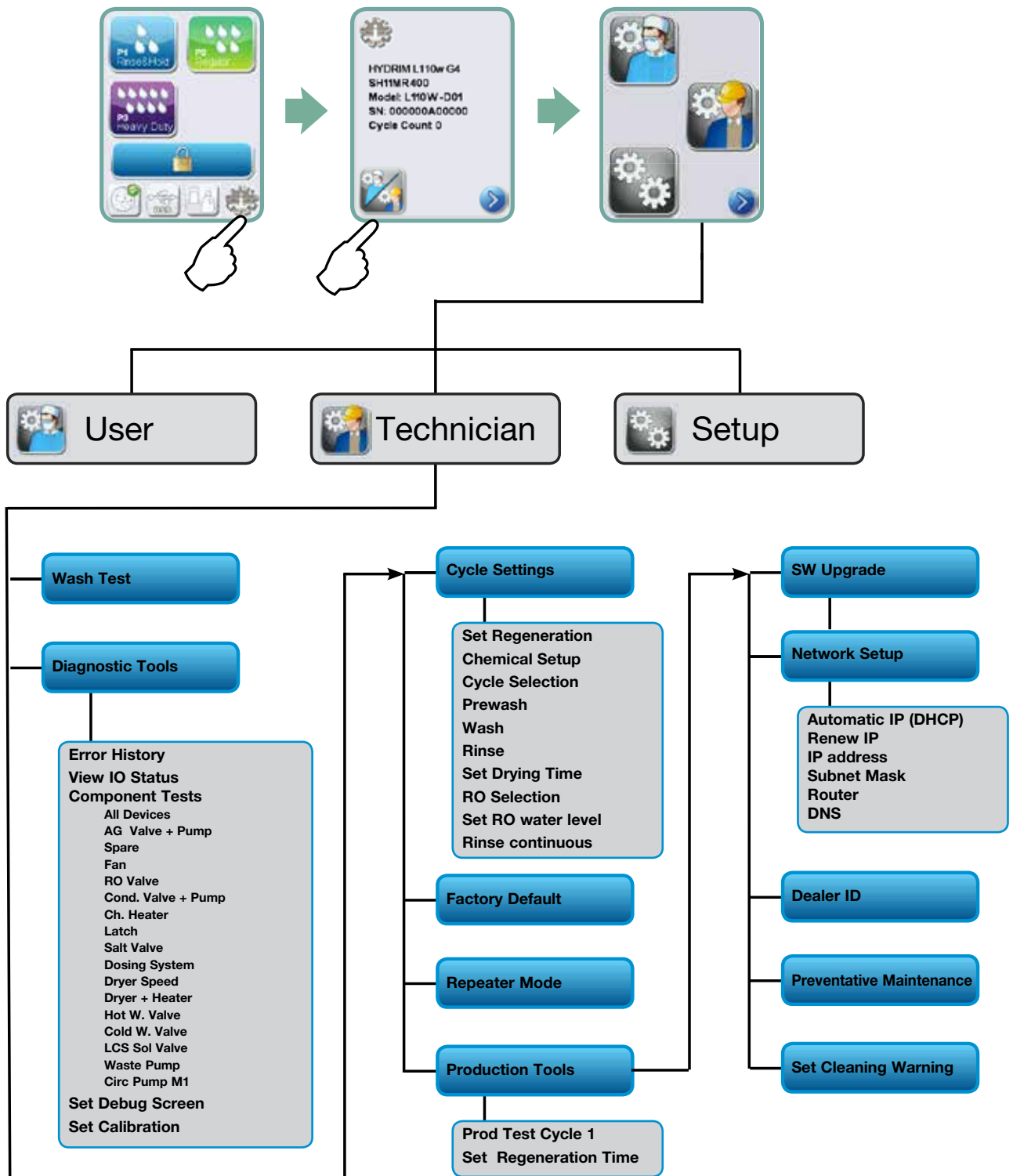

3. Diagnostics and Troubleshooting

3.2 Using the setup menu

To access functions and settings on the setup menu, proceed as follows:

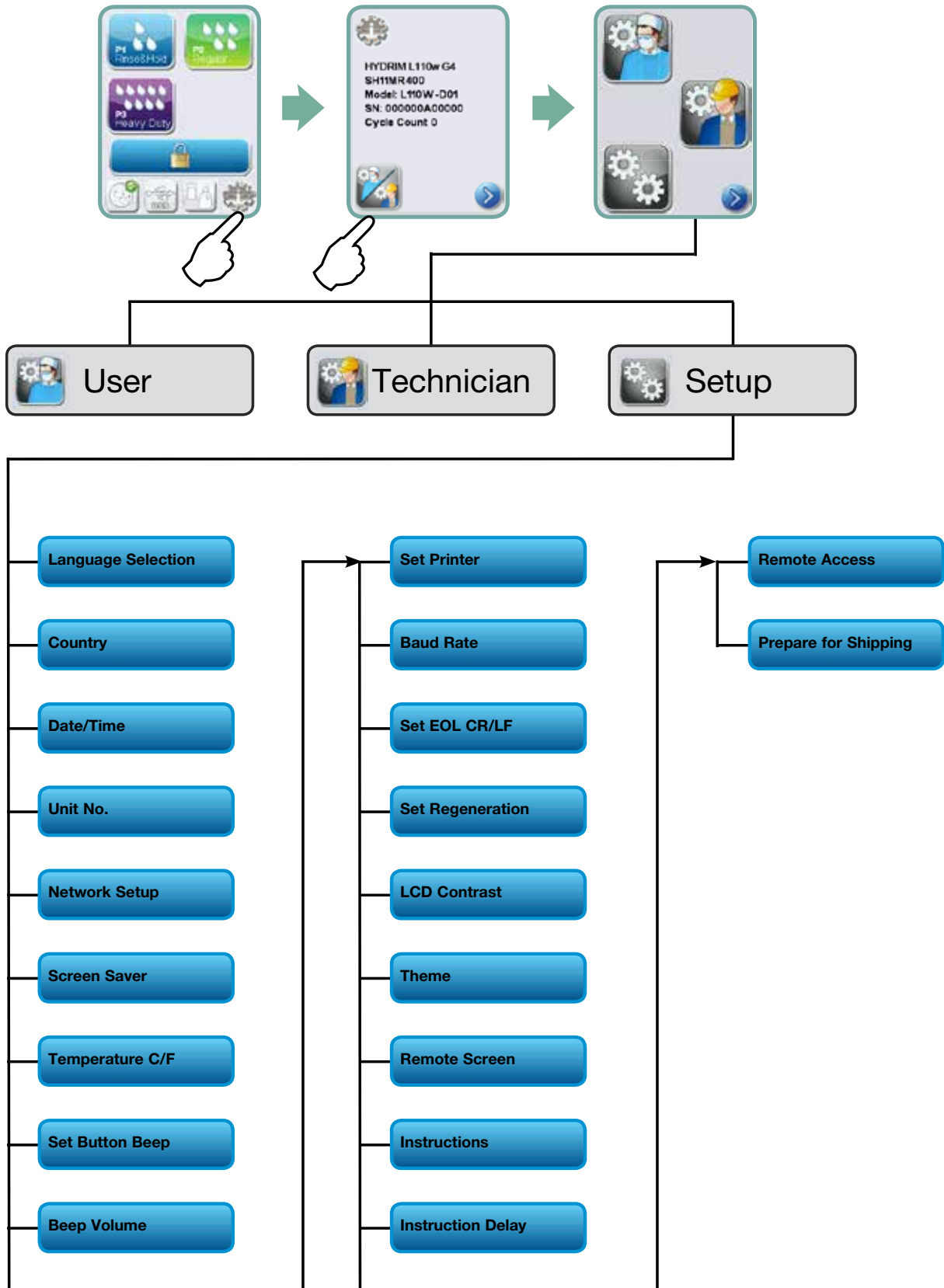

3. Diagnostics and Troubleshooting

3.3 Using the user menu

To access functions and settings on the user menu, proceed as follows:

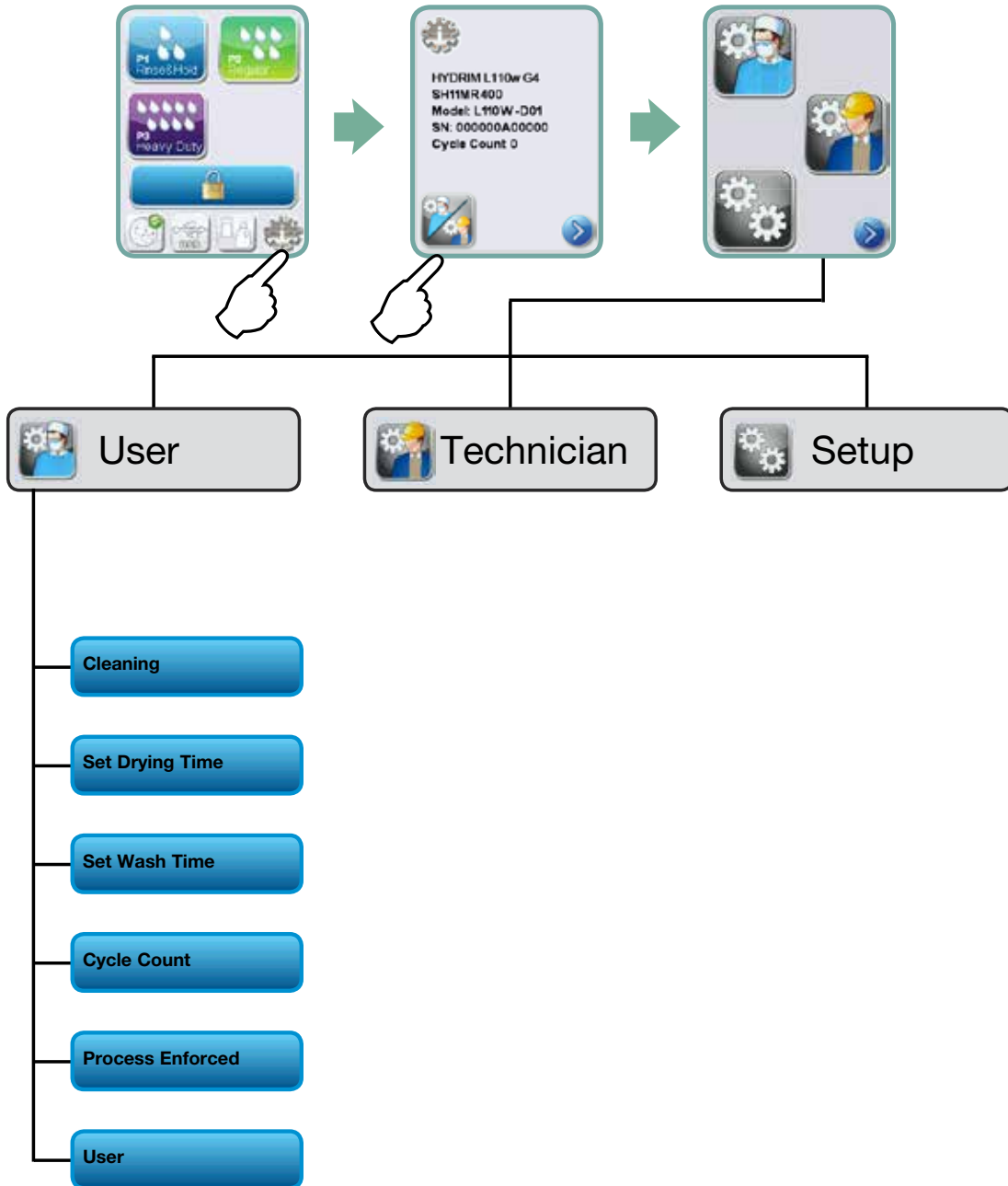

3. Diagnostics and Troubleshooting

3.4 Using software tools for diagnostics

Within the service menu, there are two useful tools for troubleshooting: Debug screen and IO status screen.

Debug Screen

The Debug screen is used when running a cycle to view the I/O status of components. Active components are colored while inactive components remain white.

To access the debug screen, select Diagnostic Tools from the service menu and select Set Debug Screen, then go to the main menu and select a cycle. The LCD screen will display the following:

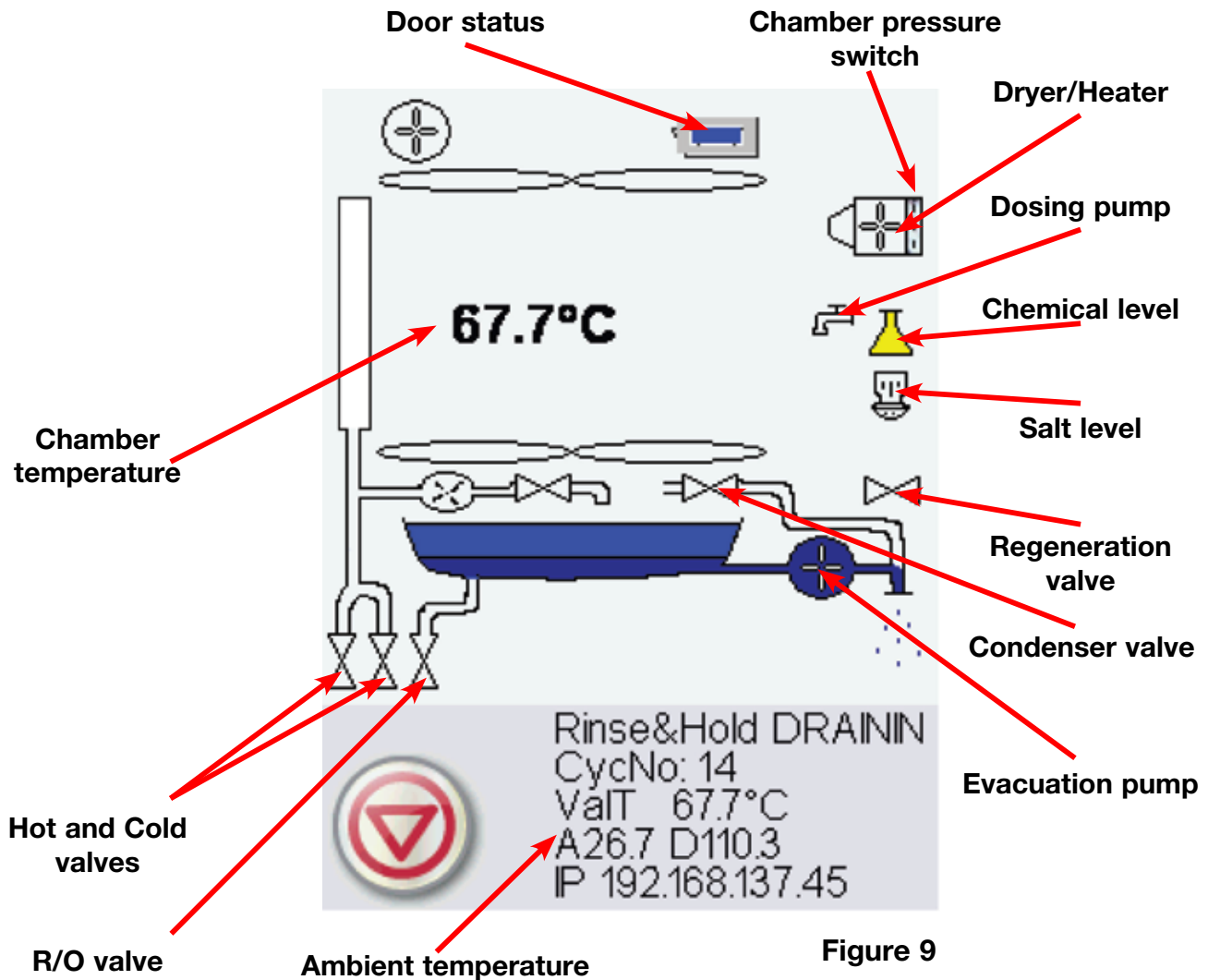

3. Diagnostics and Troubleshooting

I/O status screen

The IO status screen is used when testing components and wires for functionality without the cycle running.

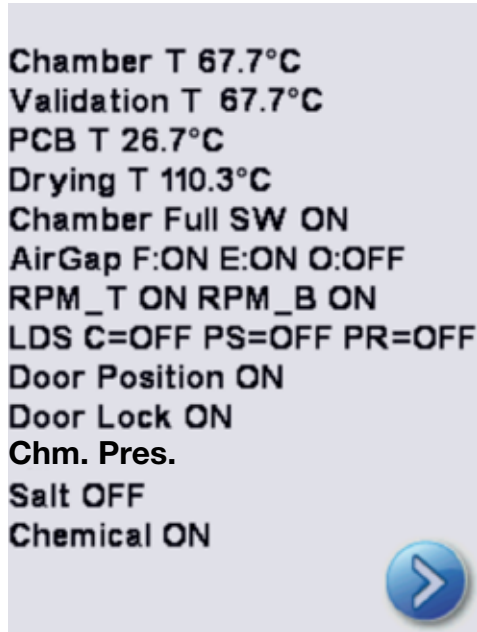

Figure 10

3. Diagnostics and Troubleshooting

3.5 Troubleshooting cycle faults

Cycle Fault	Effect	Problem	Possible Causes
CF 1 Water Heating Failure	Improper wash, cycle aborted	Chamber temperature less than a set point after a timeout, or a temperature increase rate of 1°C per 2 minutes was not achieved during “Circulation and heating” phase	This is caused by a water heater malfunction: <ul style="list-style-type: none"> • Check water heater wire harness for loose contacts. • Check for open thermal cut-off switch due to high temperature. • Check that the heater element is not interrupted. • Check I/O PCB water heater relay output.
CF 2 Chamber Filling Failure	Improper wash, cycle aborted	Timeout on filling up the chamber	<ul style="list-style-type: none"> • Water supply issue • Water valves failure • Air gap water pump failure • Air gap valve failure • Air gap Full/Empty level switches failure • Chamber water level pressure switch malfunction • Overflow switch malfunction triggering evacuation pump.
CF 3 Chamber Temperature Reading Failure	Improper wash, cycle aborted	Temperature reading outside acceptable range for primary or secondary sensor	This is caused by a temperature sensor malfunction: <ul style="list-style-type: none"> • Check temperature sensor wires for loose contacts. • Replace sensor with a good one and verify if the CF persist. • Replace I/O PCB.
CF 4 Water Evacuation Failure	Cycle interrupted	Timeout on water evacuation from the chamber	<ul style="list-style-type: none"> • Blocked drain tube • Chamber water level switch malfunction • Chamber water evacuation pump failure • Drain pump priming connection hole in the sump blocked

3. Diagnostics and Troubleshooting

Cycle Fault	Effect	Problem	Possible Causes
CF 9 Program Timeout	Cycle interrupted	The unit is running a cycle for more than 3h ±3 min.	<ul style="list-style-type: none"> Defective PCB and/or software failure Replace Color LCD controller.
CF 14 Water Too Hot	Cycle interrupted	During the Prewash phase the water temperature in the chamber is 5°C higher than the target for more than 1sec	<ul style="list-style-type: none"> Check water connections. Ensure hot and cold water inlets are not swapped.
CF 16 Ambient Temperature Error	Cycle interrupted	Operating temperature for one or both logic boards is too high	<p>The room or enclosure is too warm and not allowing the unit to adequately cool:</p> <ul style="list-style-type: none"> Check that fans are working.
CF 19 Pressure Sensor Failure	Cycle interrupted	Pressure sensor is stuck	<ul style="list-style-type: none"> Restart program. Verify that sensor is stuck closed. Verify wiring. Check I/O board for hardware failure.
CF 21 Dosing System Error	Dosing System failure Cycle interrupted	Dosing system failed to dispense the preset amount in a predefined time (time-out is 3.5s/pulse). Dosing reservoir level switch does not change from Full ON to OFF by the end of dosing (no chemical dispensed)	<p>Dosing pump or switch error:</p> <ul style="list-style-type: none"> Verify bellows dosing pump. Verify bellows dosing pump switch.
CF 25 Vref Error	Cycle cannot start or cycle interrupted	Vref and VCC drift, post CF 25 if VCC and Vref are more than 3% apart (power supply error)	<p>The power supply 5V output voltage is fluctuating:</p> <ul style="list-style-type: none"> Check power supply 5V output. Replace I/O board.
CF 27 Memory Error	Hardware failure	Color LCD control board failure	<p>The internal memory of the Color LCD Controller is malfunctioning:</p> <ul style="list-style-type: none"> Replace Color LCD controller board.
CF 28 No Water Pressure	Cycle interrupted	Not enough water during cycle	<ul style="list-style-type: none"> Check that the water hoses are not kinked. Check that water shut-off valves are open. Check for leaks. If message persists, this could be caused by stuck pressure switch or not enough water during wash phase. Check pressure sensor (stuck open). Check wiring. Check I/O board (hardware failure).

3. Diagnostics and Troubleshooting

Cycle Fault	Effect	Problem	Possible Causes
Touchscreen is blank/white			Check power source
USB storage device does not contain the last print out			<p>Re-insert the USB storage device and wait for the data to copy over again. If problem persists, back up all the information on the USB device and reformat it.</p> <p>NOTE: the web portal allows access to all of the unit's cycle information.</p>
Unit is not sending emails			<p>Check email settings by using the TEST button on the unit's web portal. From the SETUP web page, select the TOOLS tab. Click on TEST to check your router, unit, and Internet connections. If all settings appear to be OK. Go to the unit's touchscreen and renew the IP address by following these steps:</p> <ol style="list-style-type: none"> 1. Scroll through the setup menu to NETWORK SETUP and select. 2. Select RENEW IP.
Not receiving emails from the unit			Check user's spam filter. Be certain the unit has been identified as an accepted email source.

4. Removing and Replacing Panels

WARNINGS AND PRECAUTIONS

If you have questions about the unit you are repairing, please do not hesitate to contact your local SciCan representative for information. Also, the HYDRIM is heavy. Exercise caution and seek assistance when lifting or carrying units.



EXERCISE CAUTION

- Hazardous voltages are accessible when the cover is removed.
- Disconnect the power cord before servicing the power mains portion of the controller board and associated devices.
- Removing the panels will expose some sharp metal edges. Be careful and wear long sleeves and gloves.



PERFORM TESTS

- If panels are removed, a dielectric strength test (Hi-Pot) AND a protective bonding impedance test (ground continuity) must be performed on the HYDRIM when the work is completed and after the cover has been returned to the unit.
- A dielectric strength test (hi-pot) must be performed on the unit if parts associated with the power main are serviced or replaced.
- A protective bonding impedance test (ground continuity) must be performed on the unit if components of the protective earthing system are changed or if connections are broken and remade.



PROTECT THE UNIT

- The HYDRIM contains electronic circuitry that is static sensitive. Always wear a static strap when working with or near printed wiring boards. In addition, use static footstraps, grounding mats and grounded work surfaces when servicing microprocessor devices. Transport boards and devices in static protected bags.
- In order to ensure adherence to the applicable safety agency approvals, state, provincial, regional and national laws, replace components with SciCan approved parts only.

4. Removing and Replacing Panels

4.1 Removing and reinstalling the top panel

1. Turn the unit off, disconnect the power and open the door to remove 2 screws under the top panel's front edge. (Figure 11a)
2. Pull the top panel to the front and shift it left and right to release it from the tabs at the front. (Figure 11b)

NOTE: the top panel is attached to a ground wire at the back right. Tip the panel up and disconnect the ground screw to release.



Figure 11a



Figure 11b

To reinstall:

1. Reattach the ground wire, place the panel on top of the unit, slightly forward and re-engage the tabs under the front edge.
2. With the front tabs engaged, push it to the back to bring it into position.
3. Replace the 2 screws under the front edge

Cover top – part # 01-111469S

4.2 Removing and reinstalling the side and rear panels

1. Turn the unit off, disconnect the power and remove the top panel.
2. With the top panel removed, the left and right panels can be removed by pulling up to disengage them from the tabs at the bottom, then tip them back and disconnect the ground wire to remove.
3. For the rear panel, remove the two screws at the bottom, pull it up, disconnect the ground wire and remove.

To reinstall these panels, connect the ground wires and slide them down into position, engaging the tabs at the bottom of each panel into the slots in the chassis.

Cover left side - part # 01-111466S

Cover right side – part # 01-111468S

Cover rear – part # 01-111467S

5. Front Components

WARNINGS AND PRECAUTIONS

If you have questions about the unit you are repairing, please do not hesitate to contact your local SciCan representative for information. Also, the HYDRIM is heavy. Exercise caution and seek assistance when lifting or carrying units.



EXERCISE CAUTION

- Hazardous voltages are accessible when the cover is removed.
- Disconnect the power cord before servicing the power mains portion of the controller board and associated devices.
- Removing the panels will expose some sharp metal edges. Be careful and wear long sleeves and gloves.



PERFORM TESTS

- If panels are removed, a dielectric strength test (Hi-Pot) AND a protective bonding impedance test (ground continuity) must be performed on the HYDRIM when the work is completed and after the cover has been returned to the unit.
- A dielectric strength test (hi-pot) must be performed on the unit if parts associated with the power main are serviced or replaced.
- A protective bonding impedance test (ground continuity) must be performed on the unit if components of the protective earthing system are changed or if connections are broken and remade.



PROTECT THE UNIT

- The HYDRIM contains electronic circuitry that is static sensitive. Always wear a static strap when working with or near printed wiring boards. In addition, use static footstraps, grounding mats and grounded work surfaces when servicing microprocessor devices. Transport boards and devices in static protected bags.
- In order to ensure adherence to the applicable safety agency approvals, state, provincial, regional and national laws, replace components with SciCan approved parts only.

5. Front Components

5.1 Removing and reinstalling the kickplate

1. Remove the screw at the center of the kickplate. (Figure 12a)
2. Insert a flat-blade screwdriver at the top to pry it back.
3. Disconnect the ground wire at right and remove.

To reinstall, connect the ground wire, tip it back into position and fasten the center screw.

Kickplate front – part # 01-111476S.



screw

Figure 12a

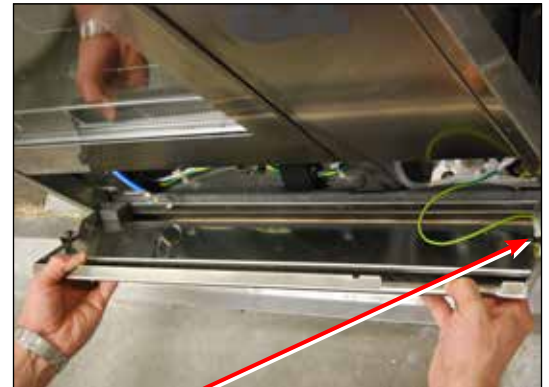

ground wire

Figure 12b

5.2 Opening the door with the manual door release

To open the door in case of a power failure, turn the unit off and remove the kickplate to access the door manual release pull-ring in the blue tube located on the left. (Figure 13)



NOTE: Exercise caution when opening the door in a power failure situation. There may be fluid remaining in the unit and instruments may be hot. Instruments that have not completed the cycle should not be used and should be reprocessed.



ring

Figure 13

5. Front Components

5.3 Removing and reinstalling the sump temperature sensor

1. Turn the unit off, disconnect the power and remove the kickplate, top and right panels.
2. Remove the coarse and fine filters inside the chamber.
3. Remove the mounting nut from the sensor inside the sump.
4. From the outside, pull the sensor out, follow the wire with red insulation jacket to the I/O board and disconnect the connector at the T1 position.

To reinstall:

1. Starting from below the sump, push the sensor wire to the I/O board and reattach it to the wiring harness ensuring it is clear of the door springs.
2. Connect sensor to I/O board.
3. Using a wrench, fasten the sensor to the sump by tightening the nut from the inside.
4. Reinstall the panels.

Single temperature sensor – part # 01-113271S

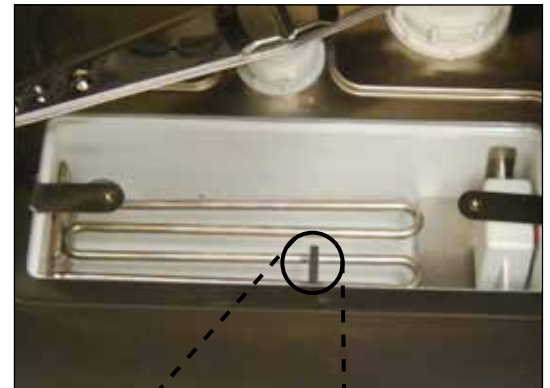

Figure 14a

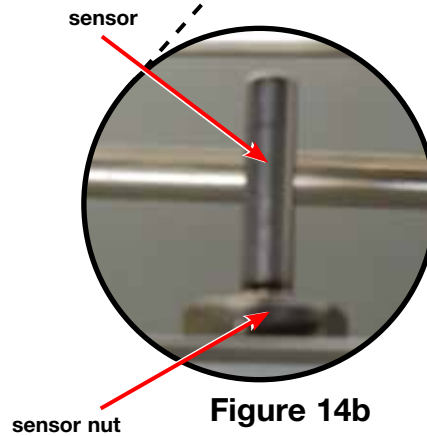

Figure 14b

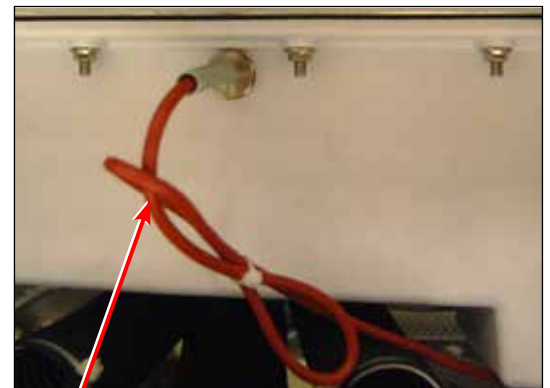

Figure 14c

sensor wire

5. Front Components

5.4 Removing and reinstalling the chemical dosing valve

1. Disconnect the chemical pouch, run a “Prepare for shipping cycle” to drain system, turn the unit off, and disconnect the power cord.
2. Remove the kickplate, top and right panels.
3. Empty the reservoir using the dosing reservoir draining tube. (Figure 15a)
4. Disconnect T-connection tubing from reservoir A and the elbow connection tubing from the chemical dosing valve. (Figure 15a)

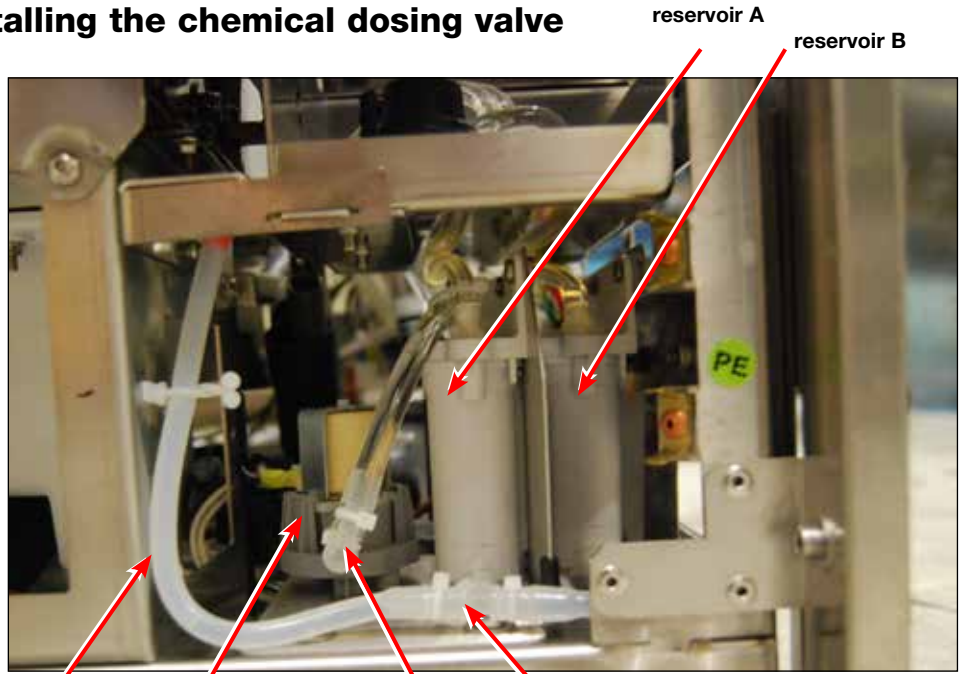

Figure 15a

5. Remove 2 screws and pull out bracket.
NOTE: The dosing reservoir has a vent tube attached. (Figure 15b)
6. Disconnect the tubing between the dosing valve and reservoir.
7. Remove the dosing valve from bracket (2 screws).

draining tube dosing valve elbow connection T-connection



Figure 15b

screws

To reinstall:

1. Fasten the dosing valve to bracket.
2. Connect the outlet tubing to the dosing valve.
3. Connect the wiring (wires 20, 27/28).
4. Connect the inlet tubing (ensure it is clear of door spring).
5. Connect tubing to reservoir.
6. Fasten the bracket screws and reinstall the kickplate and panels.

Dosing valve – part # 01-113860S



Figure 15c

5. Front Components

5.5 Removing and reinstalling the chemical reservoirs

There are two dosing reservoirs, one with a plug (reservoir A) and the other with a switch (reservoir B). A must be removed before B.

To remove reservoir A:

1. Disconnect the chemical pouch, run a "Prepare for shipping cycle" to drain system, turn the unit off, and disconnect the power cord.
2. Remove the kickplate, top and right panel.
3. Empty the reservoir using the dosing reservoir draining tube. (Figure 15a)
4. Disconnect T-connection tubing from reservoir A and the elbow connection tubing from the chemical dosing valve. (Figure 15a)
5. Remove 2 screws and pull out the bracket. **NOTE:** The dosing reservoir has a vent tube attached. (Figure 15b)
6. Disconnect tubing between the dosing valve and reservoir.
7. Remove the reservoir from bracket (2 screws).

To remove reservoir B:

1. Remove reservoir A. (See instructions above)
2. Disconnect the bracket for reservoir B by removing the two screws from the unit's right side. (Figure 16)
3. Disconnect the tubing from the reservoir to the pump and disconnect the switch wiring.
4. Pull the reservoir out and detach it from the bracket by removing the two screws.

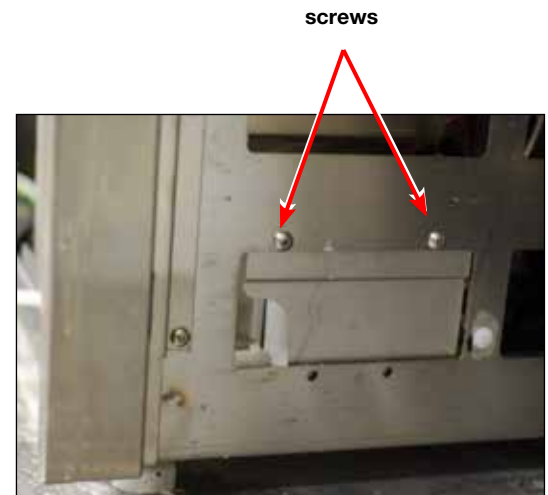

Figure 16

To reinstall:

1. Fasten reservoir B to the bracket and connect the tubing and wiring (wires 55 and 56) then fasten to chassis.
2. Fasten reservoir A to the bracket. Connect the tubing and fasten the reservoir to the chassis.
3. Reinstall the kickplate and panels

Dosing reservoir with plug (Reservoir A) – part # 01-113859S

Dosing reservoir with switch (Reservoir B) – part # 01-113858S

6. Door Components

WARNINGS AND PRECAUTIONS

If you have questions about the unit you are repairing, please do not hesitate to contact your local SciCan representative for information. Also, the HYDRIM is heavy. Exercise caution and seek assistance when lifting or carrying units.



EXERCISE CAUTION

- Hazardous voltages are accessible when the cover is removed.
- Disconnect the power cord before servicing the power mains portion of the controller board and associated devices.
- Removing the panels will expose some sharp metal edges. Be careful and wear long sleeves and gloves.



PERFORM TESTS

- If panels are removed, a dielectric strength test (Hi-Pot) AND a protective bonding impedance test (ground continuity) must be performed on the HYDRIM when the work is completed and after the cover has been returned to the unit.
- A dielectric strength test (hi-pot) must be performed on the unit if parts associated with the power main are serviced or replaced.
- A protective bonding impedance test (ground continuity) must be performed on the unit if components of the protective earthing system are changed or if connections are broken and remade.



PROTECT THE UNIT

- The HYDRIM contains electronic circuitry that is static sensitive. Always wear a static strap when working with or near printed wiring boards. In addition, use static footstraps, grounding mats and grounded work surfaces when servicing microprocessor devices. Transport boards and devices in static protected bags.
- In order to ensure adherence to the applicable safety agency approvals, state, provincial, regional and national laws, replace components with SciCan approved parts only.

6. Door Components

6.1 Removing and reinstalling the chamber seal

1. Before pulling the chamber seal, note how the bottom left and right edges touch the bottom of the chamber.
2. Pull the seal out from the seal recess.



Figure 17a

To reinstall:

1. Place the bottom left and right ends of the new seal into position, ensuring that the ends touch the chamber bottom.
2. Tuck the corners into the seal recess and push the rest of the seal into place, ensuring that it is seated evenly throughout.



Figure 17b

Main chamber seal – part # 01-113790S

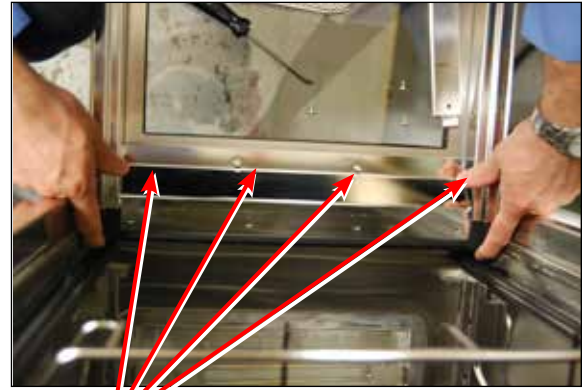

Figure 17c

6. Door Components

6.2 Removing and reinstalling the lower door seal

1. Turn the unit off.
2. Remove the 4 screws on the plate at the base of the door on the inside. (Figure 18a)
3. Remove the lower door seal.



screws

Figure 18a

To reinstall,

1. Push the door seal on tightly, ensuring that it is seated properly and evenly.
2. Re-fasten the plate to the door.



Figure 18b

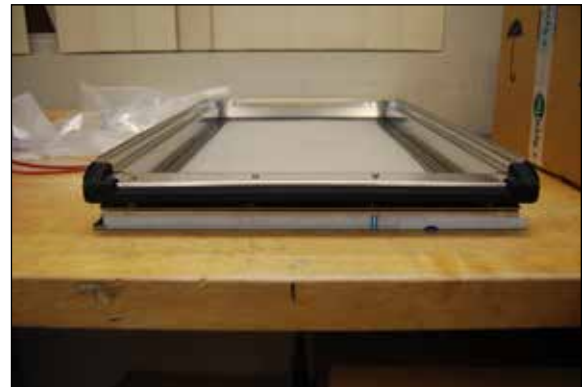

Figure 18c

Lower door seal – part # 01-113789S

6. Door Components

6.3 Removing and reinstalling the door

1. Turn the unit off.
2. Remove the 4 screws on each side. (Figure 19a)
3. Pull the door off. **CAUTION:** The right hinge is spring-loaded and will snap up.



Figure 19a

screws

To reinstall:

1. Slide the door back onto the two hinges, tipping it onto the left hinge to start and then the right hinge. Push the door until it connects with the hinge.
2. Using a flat-blade screwdriver, gently pry the hinges out to allow the door to slide into position. (Figure 19c)
3. Reinstall the screws.



Figure 19b

spring-loaded
right hinge



Figure 19c

Door wash chamber – part # 01-113836S
Hinge left – part # 01-113840S
Hinge right – part # 01-113841S

6. Door Components

6.4 Removing and reinstalling the lower door D-seal

1. Remove the door (See 6.3 Removing and reinstalling the door).
2. Remove the D-seal and remove any adhesive residue.

To reinstall, press the D-seal into place, ensuring it is seated evenly, and reattach door. **NOTE:** D-seal should protrude from the door frame on both sides by 1-2 mm (0.4-0.8 inches).

D-strip door seal - part # 01-113654S



Figure 20a



D-seal

Figure 20b

6.5 Removing and reinstalling the door latch

1. Turn the unit off, disconnect the power and remove the top panel.
2. Disconnect the door release cord and wiring from the latch assembly. (Figure 21)
3. Remove the screws from each side and remove the latch assembly. (Figure 21)

To reinstall

1. Insert the latch assembly into position.
2. Hold the latch tight to the front of the unit and reattach the screws, wiring and door release cord.
3. Run a cycle to check for leaks. To adjust the fit, slide the latch back from the door to tighten the door seal.

Door latch assembly – part # 01-111783S
Door latch cord assembly – part # 01-112080S

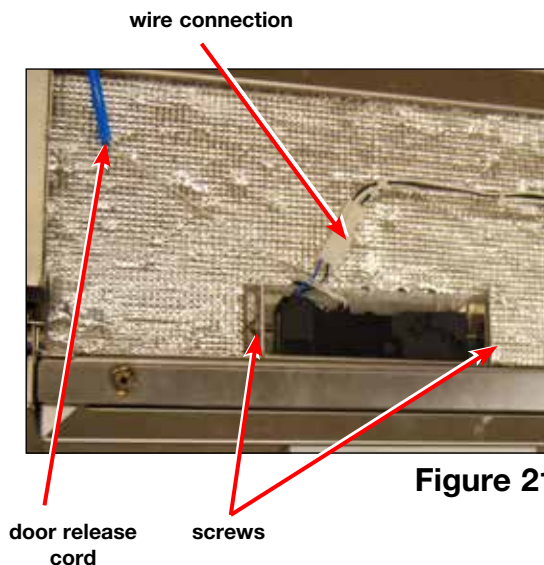

Figure 21

6. Door Components

6.6 Removing and reinstalling the door springs

1. Turn the unit off and disconnect the power.
2. Remove the top and right panels.
3. Ensure the door is closed.
4. Access the door springs from the right side to unhook. **CAUTION:** Door is heavy. To protect the technician and the unit, ensure it is correctly closed and will not accidentally fall open during this procedure.



To reinstall, reverse removal instructions.
Dual spring – part # 01-112730S

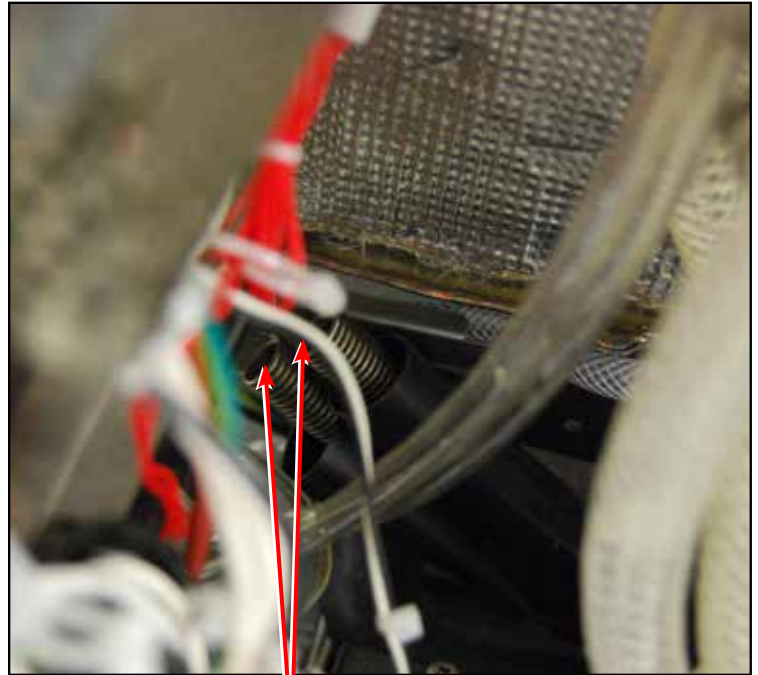

springs

Figure 22

7. Right Side Components

WARNINGS AND PRECAUTIONS

If you have questions about the unit you are repairing, please do not hesitate to contact your local SciCan representative for information. Also, the HYDR/IM is heavy. Exercise caution and seek assistance when lifting or carrying units.



EXERCISE CAUTION

- Hazardous voltages are accessible when the cover is removed.
- Disconnect the power cord before servicing the power mains portion of the controller board and associated devices.
- Removing the panels will expose some sharp metal edges. Be careful and wear long sleeves and gloves.



PERFORM TESTS

- If panels are removed, a dielectric strength test (Hi-Pot) AND a protective bonding impedance test (ground continuity) must be performed on the HYDR/IM when the work is completed and after the cover has been returned to the unit.
- A dielectric strength test (hi-pot) must be performed on the unit if parts associated with the power main are serviced or replaced.
- A protective bonding impedance test (ground continuity) must be performed on the unit if components of the protective earthing system are changed or if connections are broken and remade.



PROTECT THE UNIT

- The HYDR/IM contains electronic circuitry that is static sensitive. Always wear a static strap when working with or near printed wiring boards. In addition, use static footstraps, grounding mats and grounded work surfaces when servicing microprocessor devices. Transport boards and devices in static protected bags.
- In order to ensure adherence to the applicable safety agency approvals, state, provincial, regional and national laws, replace components with SciCan approved parts only.

7. Right Side Components

7.1 Removing and reinstalling the LCD touchscreen and LCD controller

NOTE: When installing a new LCD controller board, you must manually assign the serial number and model number. For detailed instructions on how to do this, please contact SciCan technical service.

To remove the LCD controller board:

1. Turn the unit off and disconnect the power.
2. Remove the screw above the touchscreen and tip the service panel forward to access the LCD controller. (Figure 23a)
3. Remove all wire connections from the LCD controller to the I/O board and cut cable ties affixing the wiring harness to the LCD.
4. Remove the 4 retaining nuts on each corner of the board. **CAUTION:** Lift the board gently – it is attached to the LCD by a ribbon cable. (Figure 23b)
5. Flip the board over to expose the ribbon cable latch fastener. Using your fingernail, gently flip up the latch to release the ribbon cable, and separate the LCD controller board from the LCD touchscreen. **CAUTION:** Do not use a screwdriver for this. Excess force can break the ribbon cable latch. (Figure 23c)

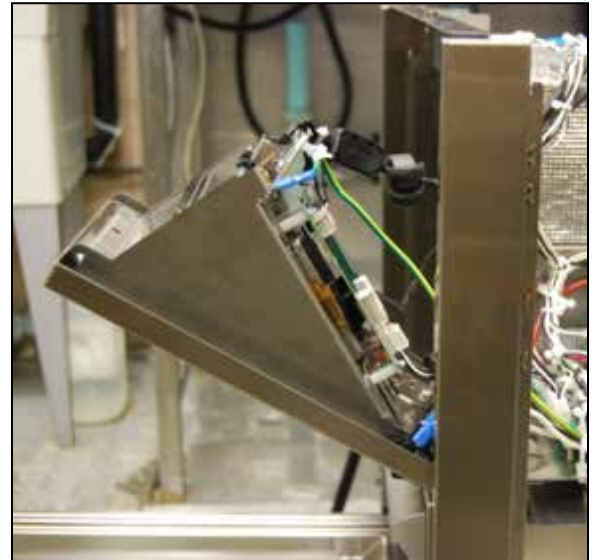

Figure 23a

retaining nuts

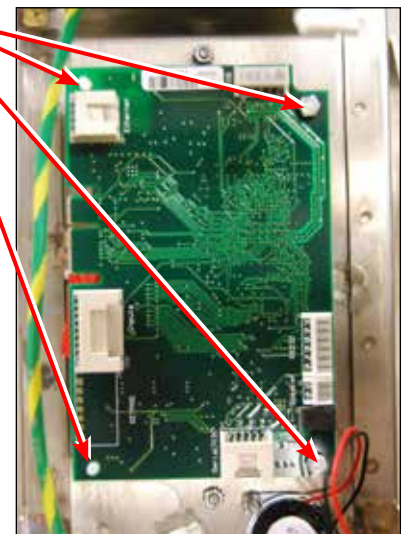

Figure 23b

ribbon cable latch



Figure 23c

ribbon cable

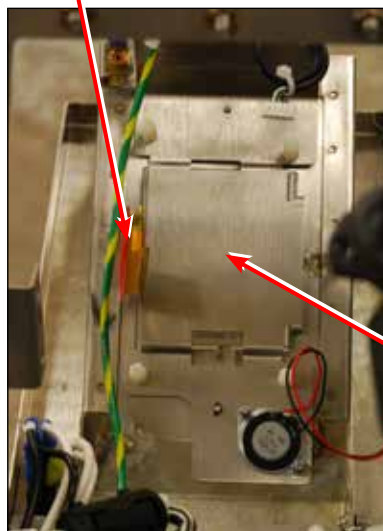

Figure 23d

LCD touchscreen bracket

7. Right Side Components

To remove the LCD touchscreen:

1. Remove the 2 retaining nuts to remove LCD bracket.
2. Separate the LCD from the bracket. The LCD may be glued or taped to the bracket. Push evenly with two thumbs to remove LCD from the bracket. (See Figure 23e).

To reinstall the LCD touchscreen:

1. Remove any residual adhesive from the LCD bracket and, using the adhesive strips supplied with the new LCD kit, set the new LCD flush with left and bottom tabs as shown in Figure 23f.
2. Reinstall LCD bracket onto the 2 threaded posts and fasten with retaining nuts.
NOTE: Remember to remove protective film from LCD.

To reinstall the LCD controller board:

1. Reconnect LCD ribbon cable to controller board. (**CAUTION:** ensure ribbon cable is properly seated into ribbon cable latch).
2. Flip the board onto the four threaded posts and fasten with retaining nuts.
3. Reconnect the wire connectors.

NOTE: When installing a new LCD controller board, you must manually assign the serial number and model number. For detailed instructions on how to do this, please contact SciCan technical service.

LCD assembly - part # 01-113856S
Colour LCD controller, L110w – part # 01-113665S

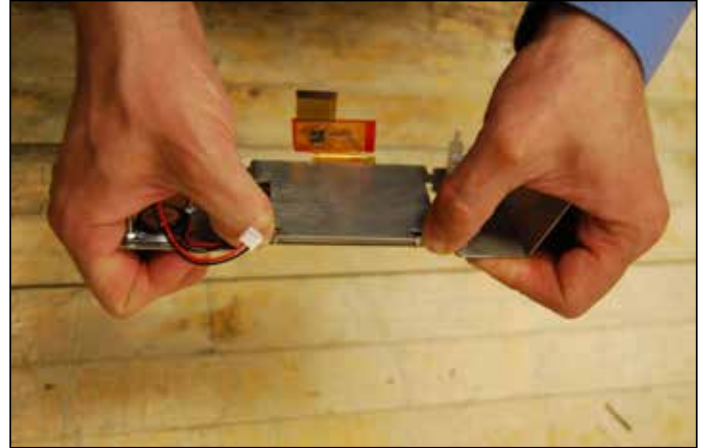

Figure 23e

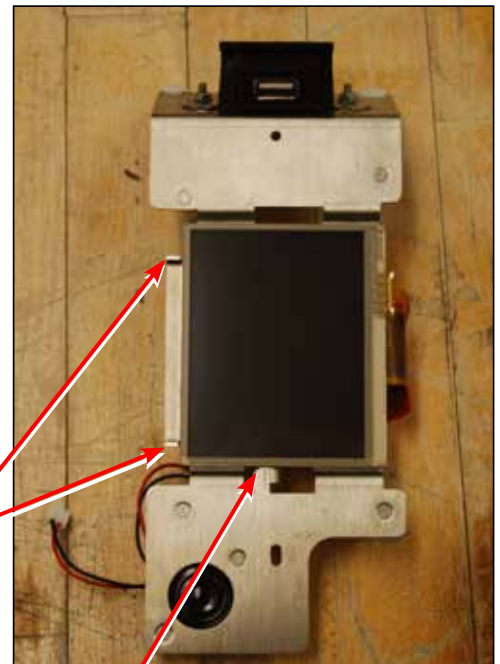

Figure 23f

bottom
alignment
tab

left
alignment
tabs

7. Right Side Components

7.2 Removing and reinstalling the I/O board

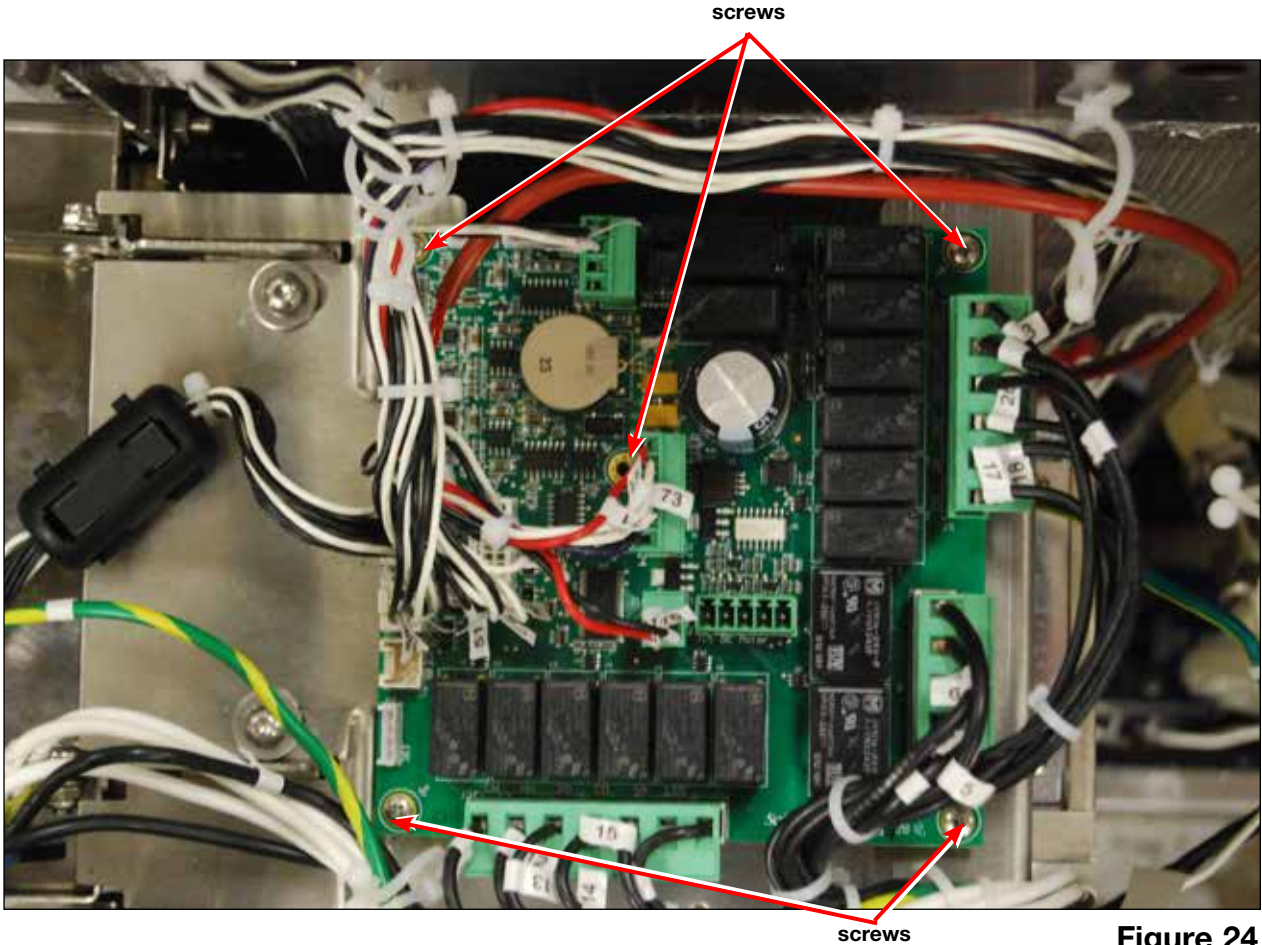

Figure 24

1. Turn the unit off, disconnect from power and remove the top and right panel.
2. Disconnect all connectors on I/O board.
3. Remove the 5 screws fastening I/O board.

To reinstall:

1. Ensure the unit is disconnected from power source.
2. With I/O board in place, reinstall the 5 screws.
3. Reconnect all connectors. **NOTE:** all connectors have unique ports. See Figure 24 and the electrical schematic in Appendix A for reference.

IO PCB – part # 01-113310S

7. Right Side Components

7.3 Removing and reinstalling the power supply

1. Turn off the unit and disconnect the power cord.
2. Remove the wire contacts from the power supply.
3. Loosen the screw at the top left of the power supply bracket and remove the screw at the bottom right.
4. Slide power supply down to remove.

To reinstall:

1. Slide the bracket back into position, tighten screws.
2. Reattach contacts according to Figure 25b.

Power supply 5V/24V – part # 01-113266S

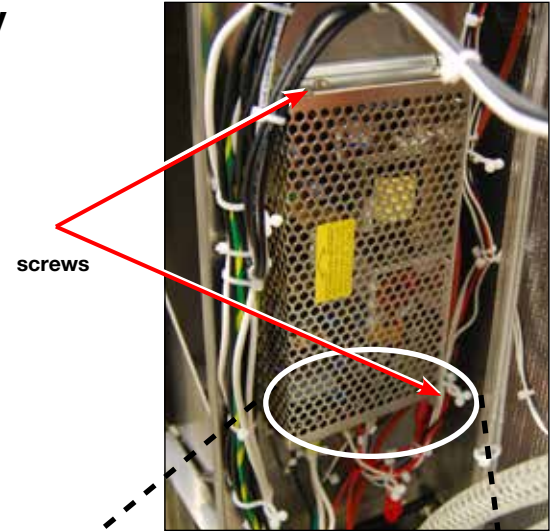

Figure 25a

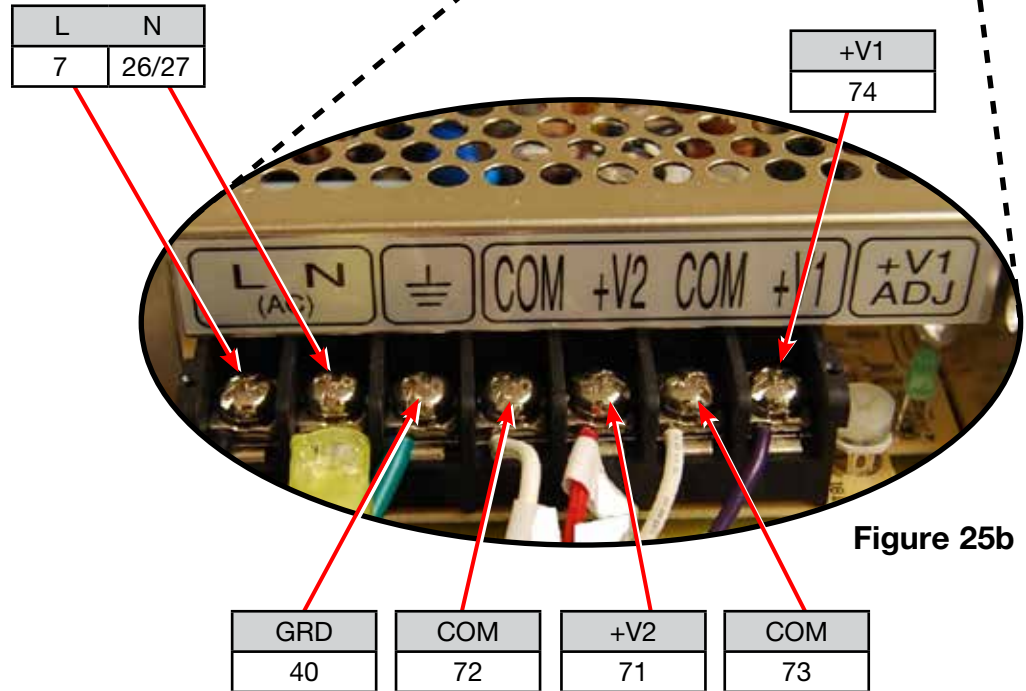

Figure 25b

7. Right Side Components

7.4 Removing and reinstalling the dosing pump

1. Disconnect the chemical pouch, run a "Prepare for shipping cycle" to drain system, turn the unit off, and disconnect the power cord.
2. Remove the kickplate and drain the detergent reservoirs using the drain tube.
3. Remove the top and right panel.
4. Disconnect the wires from the microswitch.
5. Disconnect the pump wires.
6. Disconnect the outlet tube at the chamber connection.
7. Disconnect the inlet tube.
8. To remove the pump, remove the bracket screw on the outside edge of the pump and loosen the bracket screw on the chamber side.
9. Slide the pump to the outside edge and pull it out with the outlet tube still attached.

To reinstall:

1. Install the pump.
2. Connect the outlet and inlet tubes.
3. Connect the pump wires: yellow wire to 21 and white wire to 28/29.
4. Connect the microswitch wires: black wire to 53 and white wire to 54.
5. Reinstall the panels.

Dosing pump – part # 01-113837S

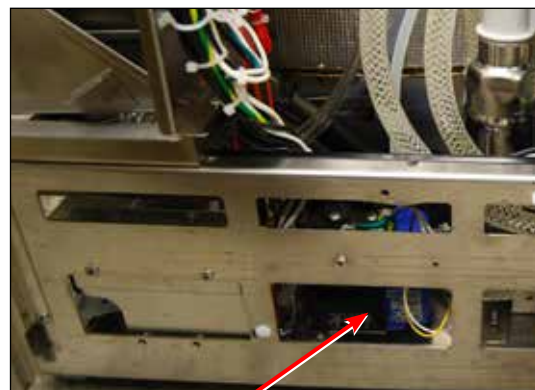

dosing pump

Figure 26a

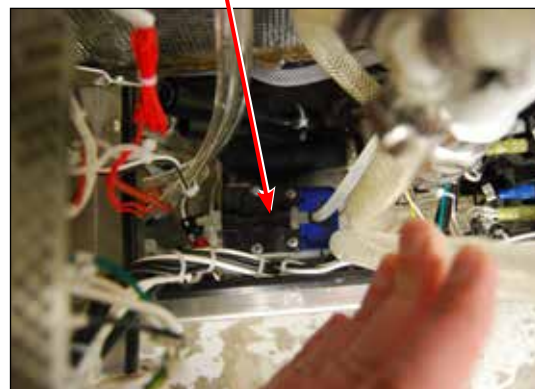

Figure 26b

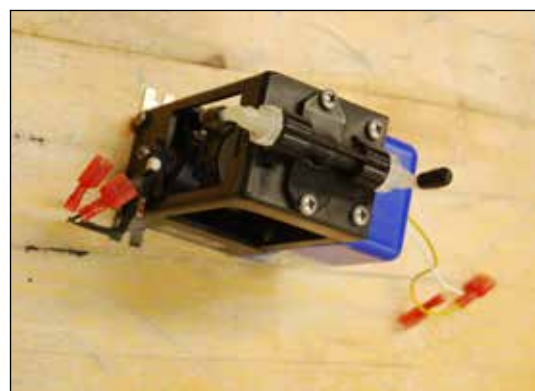

Figure 26c

7. Right Side Components

7.5 Removing and reinstalling the chamber level/overflow switch

1. Turn the unit off, disconnect the power and remove the top and right panels.
2. Remove the wiring from the switch.
3. Disconnect the tubing.
4. Remove the screw fastening the switch bracket to the unit and remove the switch and bracket.

To reinstall:

1. Before reattaching the pressure switch's male end to the tubing, use a syringe to pump a small amount of air into the tube. This will purge any fluid from the tube.
2. Reattach the bracket and switch to the unit.
3. Reattach the tubing.
4. Reconnect the wiring according to Figure 27b.

Chamber level switch – part # 01-111408S

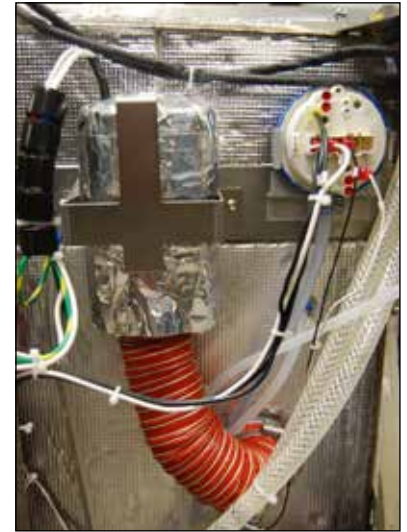

Figure 27a

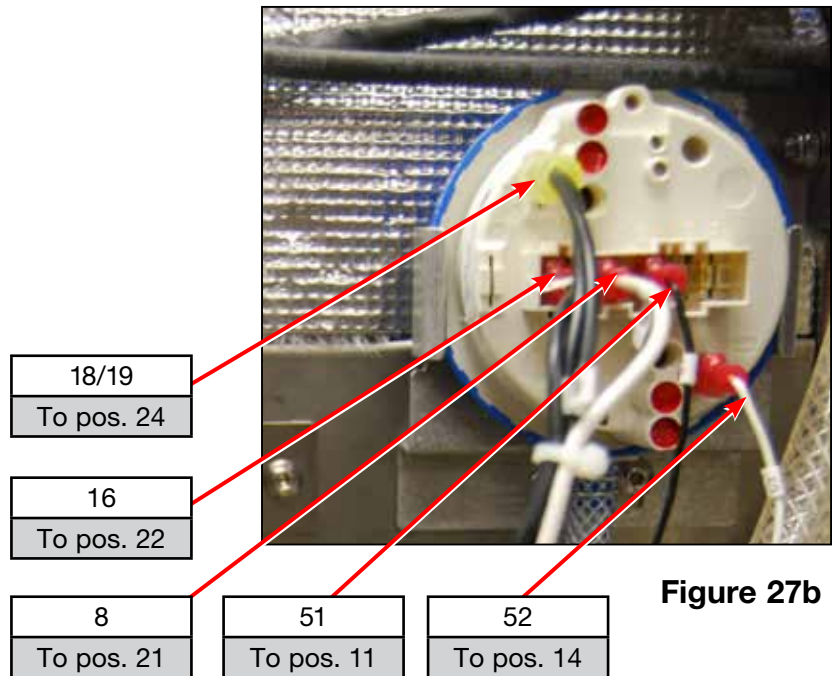

Figure 27b

7. Right Side Components

7.6 Removing and reinstalling the drain pump and exhaust assembly

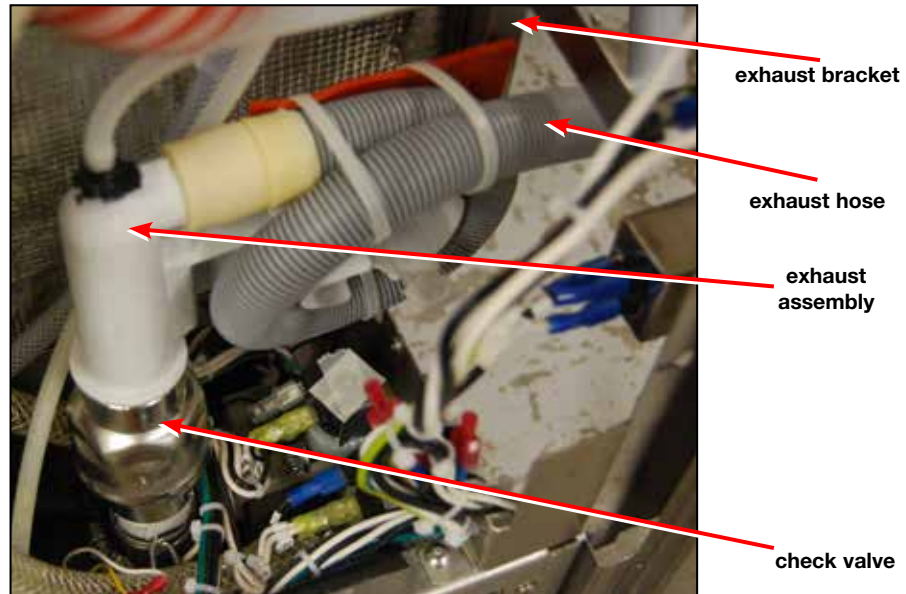
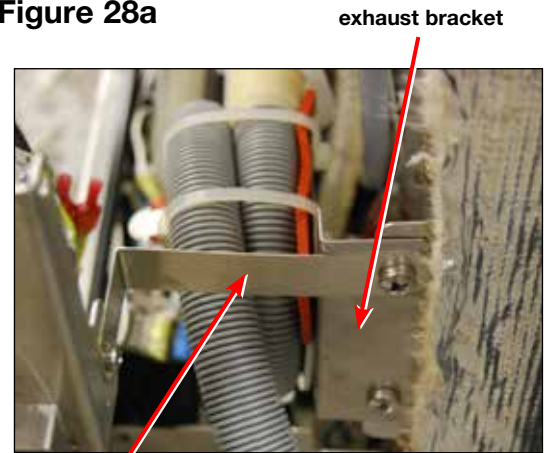

Figure 28a



1. Turn the unit off and disconnect the power.
CAUTION: Water will remain in the drain assembly. Suction out any remaining water.
2. Remove the top cover, right and rear panels.
3. Remove the horizontal brace. (Figure 28b)
4. Remove the exhaust assembly bracket. (Figure 28b)
5. Loosen the hose clamp from pump outlet. (Figure 28c)
6. Remove the exhaust assembly.
7. Loosen the hose clamp from inlet of pump and remove the 2 screws holding pump to bracket. (Figure 28c)
8. Disconnect the wires and remove the pump.



horizontal brace

Figure 28b

To reinstall the drain pump:

1. Put the pump into position and tighten the hose clamp connecting the inlet tube.
2. Connect the pump wiring.
3. Fasten the pump (2 screws) to the pump bracket.
4. Reattach the exhaust assembly and tighten the hose clamp on the outlet.
5. Reattach the exhaust assembly bracket to the chassis. Reattach the horizontal brace.

Drain pump – part # 01-111412S
 Drain tube – part # 01-113851S
 Check valve 1" – 01-113867S

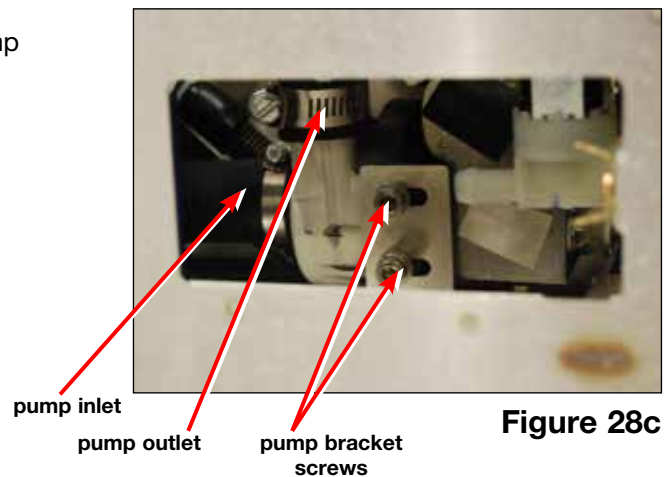

pump inlet
 pump outlet
 pump bracket screws

Figure 28c

7. Right Side Components

7.7 Removing and reinstalling the dryer motor

1. Turn the unit off, disconnect the power and remove the top cover and right panel.
2. Remove the 2 screws on dryer motor bracket to release the dryer motor.
3. Remove the protective sleeve and disconnect the wiring.
4. Loosen the hose clamp between the dryer hose to the dryer motor and disconnect and remove the dryer.

To reinstall:

1. Connect the dryer motor to the dryer hose and tighten hose clamp.
2. Attach the dryer motor to the unit using the dryer motor bracket. (2 screws)
3. Connect the wires following the colour code indicated on the dryer motor (white to white (25/26); red to red (6); blue to blue (22)), and reattach the protective sleeve.

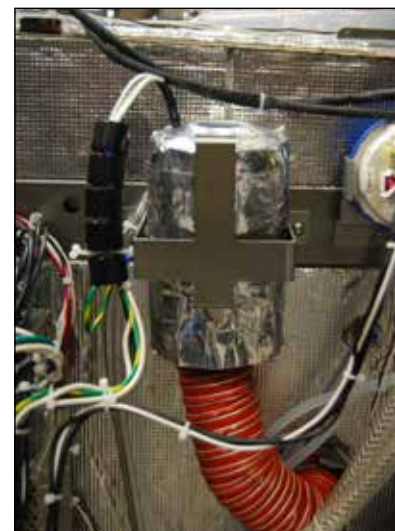

Figure 29a

Dryer assembly –
part # 01-109142S

Dryer fitting –
part # 01-109144S

Dryer tubing –
part # 01-109143S

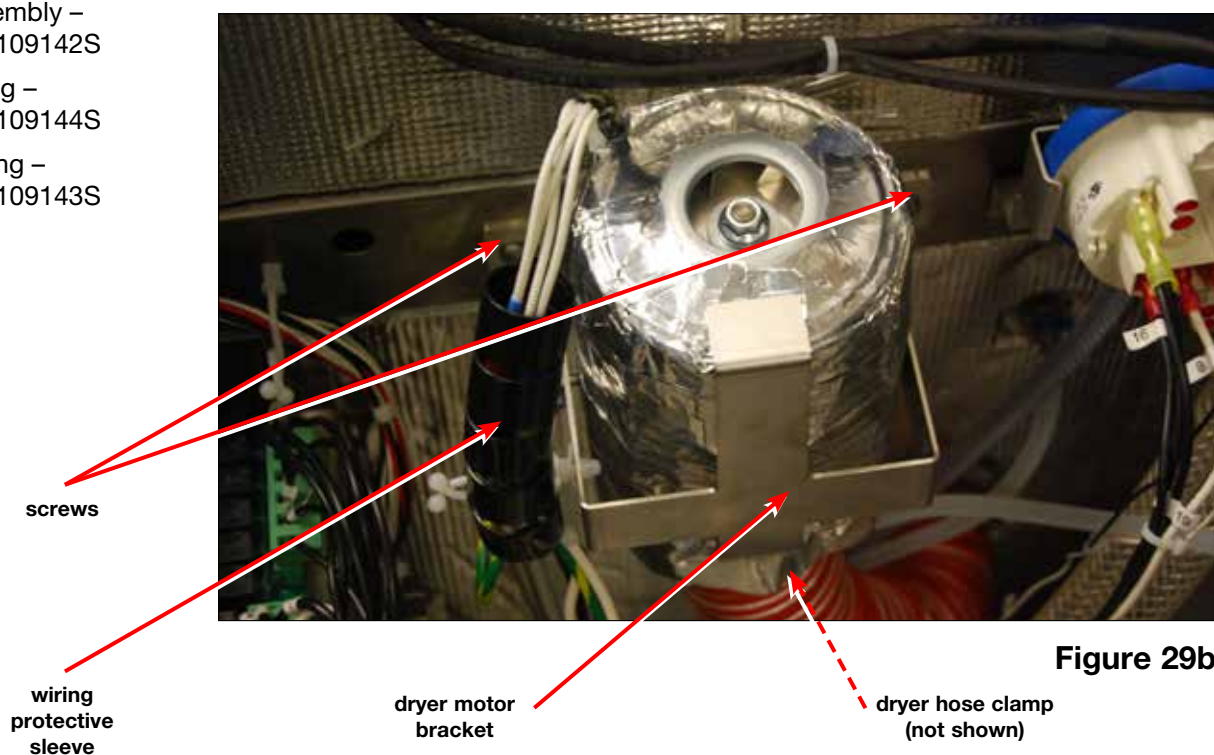

Figure 29b

7. Right Side Components

7.8 Removing and reinstalling the power switch

1. Turn off the unit and disconnect the power.
2. Remove the screw above the LCD touchscreen.
3. Open the service panel.
4. Disconnect the wires from the power switch and press down the locking tabs to remove, pushing the switch through the panel.

To reinstall, push the switch into position and reconnect wiring according to Figure 30b. Be sure to pull out the locking tabs at the top left and bottom right as shown in Figure 30a.

Rocker switch – part # 01-112024S

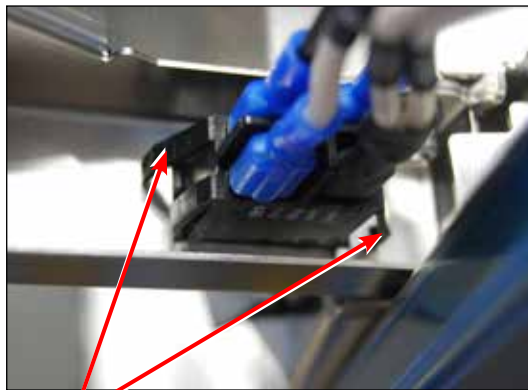

Pull tabs out

Figure 30a

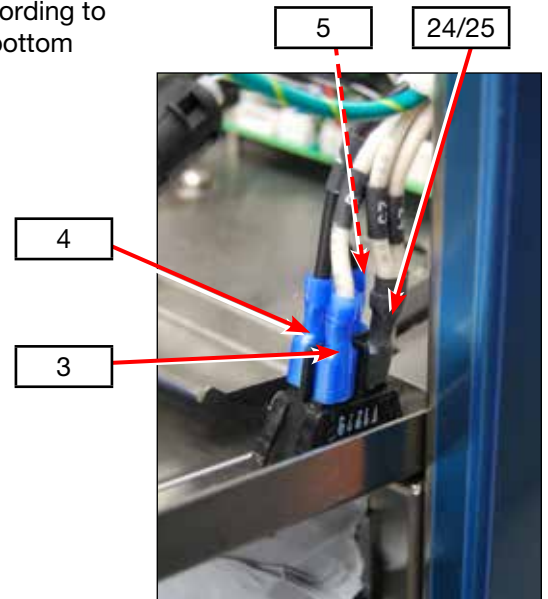

Figure 30b

7.9 Removing and reinstalling the USB port

1. Turn unit off and disconnect the power.
2. Remove the screw above the touchscreen to tip open the service panel.
3. Remove the retaining nuts from the threaded posts, remove the bracket and disconnect the USB port from the LCD touchscreen controller board.

To reinstall, reverse removal instructions.

Cable USB – part # 01-112398S

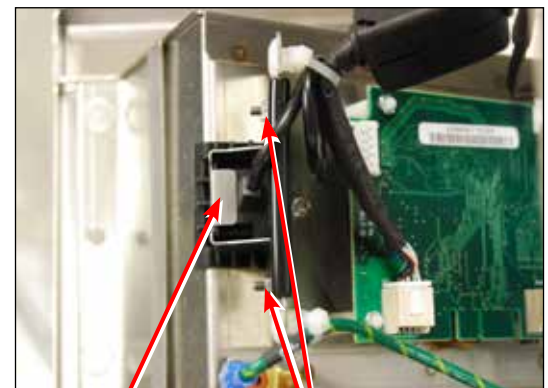

USB port

retaining nuts

Figure 31

8. Left Side Components

WARNINGS AND PRECAUTIONS

If you have questions about the unit you are repairing, please do not hesitate to contact your local SciCan representative for information. Also, the HYDRIM is heavy. Exercise caution and seek assistance when lifting or carrying units.



EXERCISE CAUTION

- Hazardous voltages are accessible when the cover is removed.
- Disconnect the power cord before servicing the power mains portion of the controller board and associated devices.
- Removing the panels will expose some sharp metal edges. Be careful and wear long sleeves and gloves.



PERFORM TESTS

- If panels are removed, a dielectric strength test (Hi-Pot) AND a protective bonding impedance test (ground continuity) must be performed on the HYDRIM when the work is completed and after the cover has been returned to the unit.
- A dielectric strength test (hi-pot) must be performed on the unit if parts associated with the power main are serviced or replaced.
- A protective bonding impedance test (ground continuity) must be performed on the unit if components of the protective earthing system are changed or if connections are broken and remade.



PROTECT THE UNIT

- The HYDRIM contains electronic circuitry that is static sensitive. Always wear a static strap when working with or near printed wiring boards. In addition, use static footstraps, grounding mats and grounded work surfaces when servicing microprocessor devices. Transport boards and devices in static protected bags.
- In order to ensure adherence to the applicable safety agency approvals, state, provincial, regional and national laws, replace components with SciCan approved parts only.

8. Left Side Components

8.1 Removing and reinstalling the sump water heater



1. Turn the unit off and disconnect the power.
CAUTION: Water will remain in the drain assembly. Suction out any remaining water.
2. Remove the top cover and left panel.
3. Disconnect the wiring.
4. Remove the 4 retaining nuts and remove the plate.
5. From inside the chamber, remove the coarse and fine filters and pull the heater out from the sump side.

To reinstall:

1. Reinstall the gasket on the heater's base and insert it into position from the sump side.
2. From the left side of the unit, put the heater plate into position and fasten using the retaining nuts.
3. Connect the wiring, see Figure 32b.
4. Reinstall the panels.

Water heater HYDRIM –
part # 01-113839S



Figure 32a

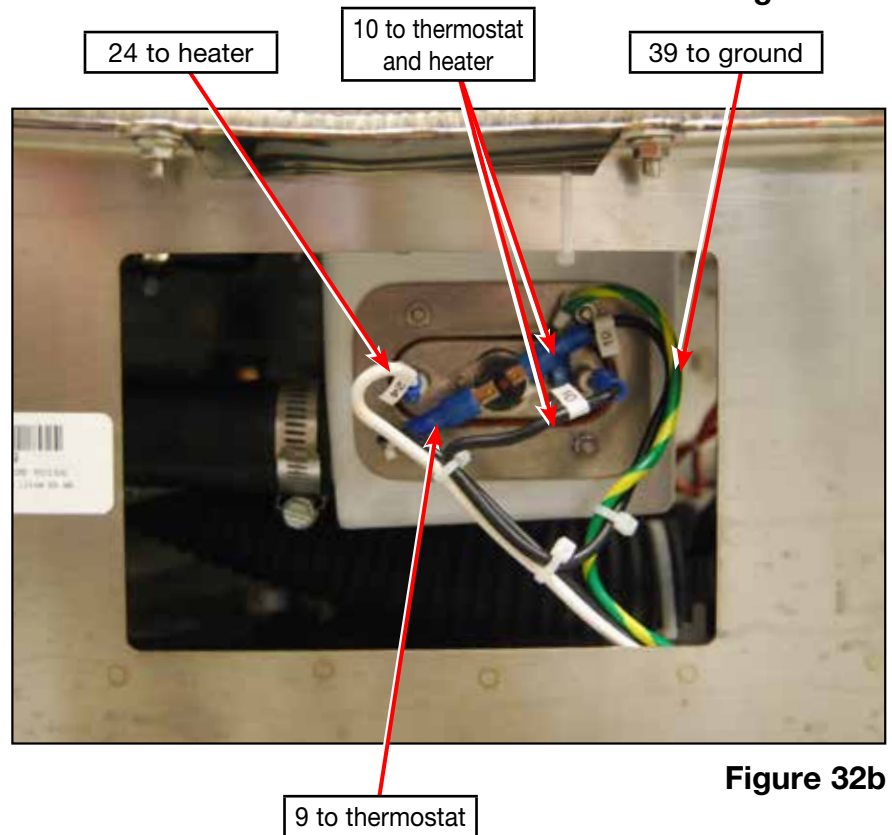

Figure 32b

8. Left Side Components

8.2 Removing and reinstalling recirculation pump



1. Turn the unit off and disconnect the power.
CAUTION: Water will remain in the drain assembly. Suction out any remaining water.
2. Remove the top, rear and left panels.
3. Disconnect the rear kickplate by removing the screws on either side. (Figure 33a)
4. Remove the kickplate from the front and cut the cable ties fastening the air vent outlets.
5. From the back, pull the air vent outlets out of the way.
6. Disconnect the pump wires.
7. Place an absorbent cloth under the pump to catch residual water and loosen hose clamp to disconnect outlet hose at the pump side.
8. From the left side of the unit, loosen the hose clamp to disconnect the inlet hose at the pump side.
9. From left side of the unit, disconnect the capacitor wires. (Figure 33b)
10. From the rear of the unit, remove the 3 screws fastening the bracket. (Figure 33c)
11. Pull the pump out and separate the pump from the bracket.

To reinstall:

1. Install new pump onto the bracket. **NOTE:** Use the new vibration mount that comes with the new pump.
2. Reattach the pump to the inlet and outlet tubings and tighten the hose clamps.
3. Fasten the bracket into place.
4. Attach the wiring and capacitor wires.
5. Thread the air vents back through to the front and fasten with new cable ties.
6. Reinstall the panels.

Circulation pump –
part # 01-111465S



screw pump screw **Figure 33a**

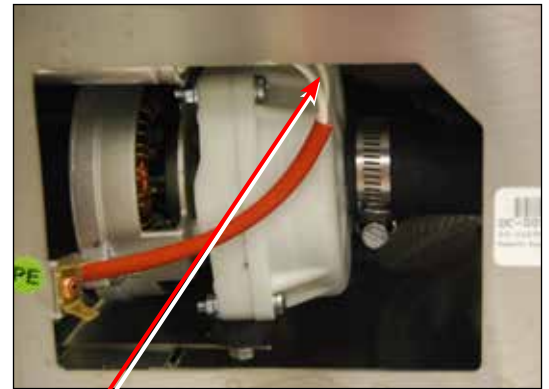

capacitor wires

Figure 33b

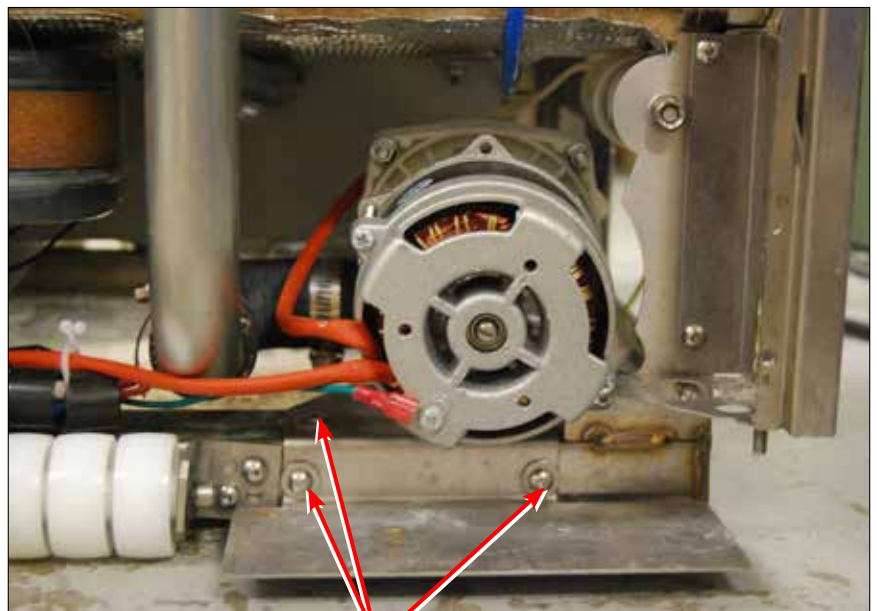

screws

Figure 33c

9. Rear Components

WARNINGS AND PRECAUTIONS

If you have questions about the unit you are repairing, please do not hesitate to contact your local SciCan representative for information. Also, the HYDRIM is heavy. Exercise caution and seek assistance when lifting or carrying units.



EXERCISE CAUTION

- Hazardous voltages are accessible when the cover is removed.
- Disconnect the power cord before servicing the power mains portion of the controller board and associated devices.
- Removing the panels will expose some sharp metal edges. Be careful and wear long sleeves and gloves.



PERFORM TESTS

- If panels are removed, a dielectric strength test (Hi-Pot) AND a protective bonding impedance test (ground continuity) must be performed on the HYDRIM when the work is completed and after the cover has been returned to the unit.
- A dielectric strength test (hi-pot) must be performed on the unit if parts associated with the power main are serviced or replaced.
- A protective bonding impedance test (ground continuity) must be performed on the unit if components of the protective earthing system are changed or if connections are broken and remade.



PROTECT THE UNIT

- The HYDRIM contains electronic circuitry that is static sensitive. Always wear a static strap when working with or near printed wiring boards. In addition, use static footstraps, grounding mats and grounded work surfaces when servicing microprocessor devices. Transport boards and devices in static protected bags.
- In order to ensure adherence to the applicable safety agency approvals, state, provincial, regional and national laws, replace components with SciCan approved parts only.

9. Rear Components

9.1 Removing and reinstalling the Ethernet and RS232 ports

1. Disconnect the power and remove the top cover and back panel.
2. To remove Ethernet port, remove the screw on the left of the port, disengage the tab from the bracket, and disconnect the wiring from the I/O board.
3. To remove the RS232 port, remove the fastening nuts, and disconnect wiring from the LCD controller board.

To replace, reverse removal instructions.

Cable, Ethernet – part # 01-113854S

Cable, RS232 port – part #01-113260S

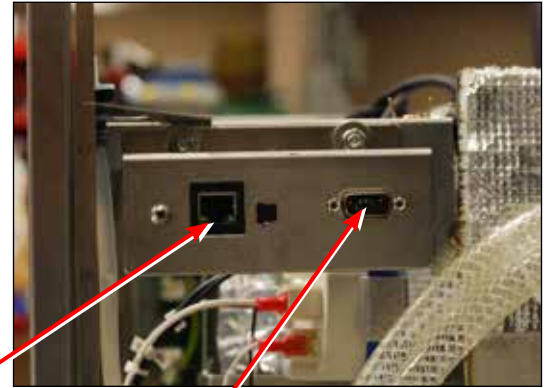

cable ethernet

cable RS232 port

Figure 33a

9.2 Removing and reinstalling the chamber pressure switch

1. Turn the unit off, disconnect the power and remove the top and rear panels.
2. Disconnect the wiring from the chamber pressure switch.
3. Loosen the hose clamp and remove the chamber pressure switch from the metal tubing.

To reinstall:

1. Push the chamber pressure switch onto metal tubing and fasten with the hose clamp.
2. Reconnect wiring. (Figure 34b)

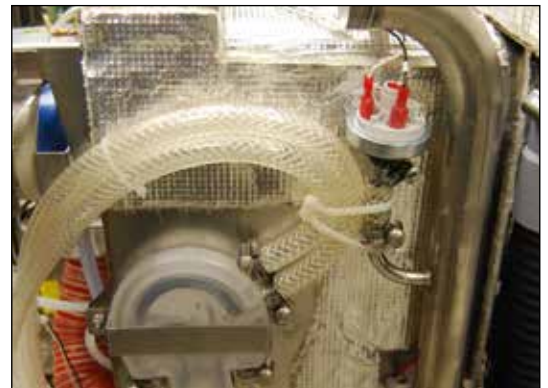

Figure 34a

Chamber pressure switch – part # 01-111409S

60 to pos. 3

59 to pos. 1

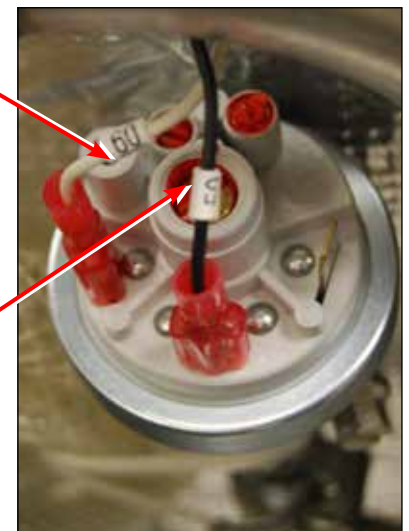

Figure 34b

9. Rear Components

9.3 Removing and reinstalling the water softener system

1. Turn unit off and disconnect power.
2. Remove the top, rear and left panels.
3. From inside the chamber, remove cap and siphon remaining water from water softener system.
4. From the unit's right side, locate and disconnect the sensor wire. (Figure 35a)
5. At the rear of the unit, number the hoses according to the numbers embossed on the air break. (Figure 35b).
6. From inside the chamber, remove the water softener system mounting nut. (Figure 35c)
7. From the rear of the unit, pull the water softener out. (Figure 35d)
8. Disconnect hoses (hoses may need to be heated to be removed).



sensor wire

Figure 35a

To reinstall:

1. Connect hoses matching the hose number to the number embossed on the water softener.
2. Position water softening system and from the chamber side, fasten the mounting nut tightly.
NOTE: The mounting nut should not be tightened by hand. Use a tool to get a good seal.
3. Connect the sensor wire.
4. To refill the water softener, unscrew the salt container lid and pour 1 litre / 1 quart of water into the water softener.
Add 1 kg / 22 lbs of water softening salt in the same manner. Screw the salt container cap on tightly.
5. Reinstall panels.



Figure 35b



mounting nut

Figure 35c

Water softener –
part # 01-113857S



Figure 35d



Figure 35e

9. Rear Components

9.4 Removing and reinstalling the air break

1. Turn the unit off and disconnect the power.
2. Remove top and rear panels.
3. Remove the air break bracket.
4. Number the hoses according to the numbers embossed on the air break. (Figure 36b)
5. Remove the hoses.
6. From inside the chamber, remove the mounting nut. (Figure 36c)
7. Remove the air break.

To reinstall:

1. Reconnect the hoses, matching the numbers on the hoses to the numbers embossed on the air break.
2. Put the air break into position and fasten the mounting nut from the inside. **NOTE:** The mounting nut should not be tightened by hand. Use a tool to get a good seal.
3. Reinstall air break bracket.
4. Reinstall panels.

Air break – part # 01-113830S

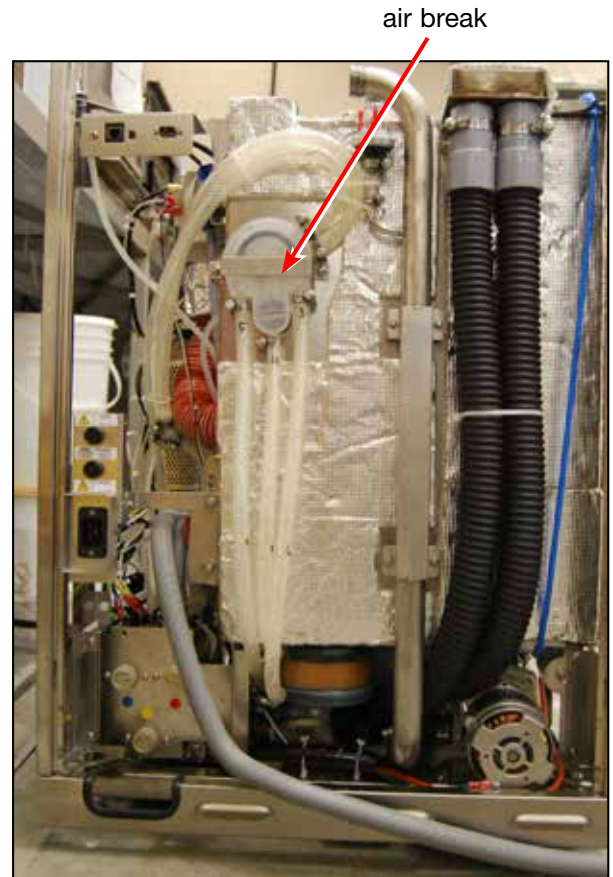

Figure 36a

mounting nut



Figure 36b



Figure 36c

9. Rear Components

9.5 Removing and reinstalling the water inlet valves

1. Turn the unit off and disconnect the power.
2. Remove the top, right and rear panels.
3. Valves for hot water, cold water and R/O water inlets can be accessed from the rear and right side of the unit.
4. Disconnect the wiring.
5. Remove the fastening screws to remove a valve from the bracket.
6. Disconnect the tubing.

Valve	Color Coding	Wiring	
Cold water inlet	Blue	11	31/32
Regeneration valve	Blue	15	35/36
Hot water inlet	Red	12	33/34
R/O water inlet	Yellow	13	32/33

To reinstall, reverse instructions.

Cold: Valve 1 in, 2 out – part # 01-113331S

Hot: Valve 1 in, 1 out – part # 01-113330S

RO: Valve 1 in, 1 out – part # 01-113330S

Inlet hose (cold, hot) NA - part # 01-107788S

Inlet hose (RO) NA – part # 01-113863S

hot water inlet

cold water inlet

R/O water inlet

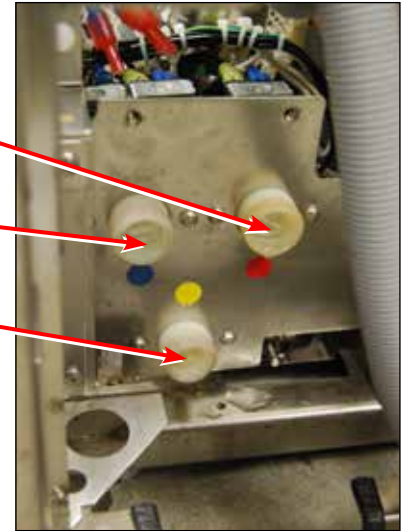

Figure 37a

hot water valve

cold water valve

regeneration valve

RO valve
(not shown)

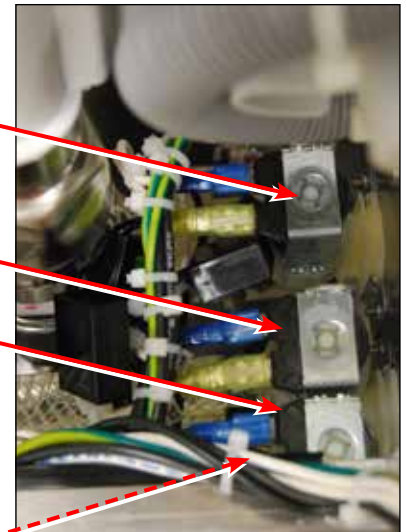

Figure 37b

9. Rear Components

9.6 Removing and reinstalling the fuses and fuse holders

1. Turn the unit off, disconnect the power and remove top and rear panels.
2. For continued protection against the risk of fire, replace fuses with 15A, 250V type F only.
3. To remove fuse holders, disconnect wires and remove mounting nut fastening holder to bracket.

To replace, reverse instructions and reference Figure 38a for wire connections.

Fuse 15 A (2 pcs) – part # 01-103472S

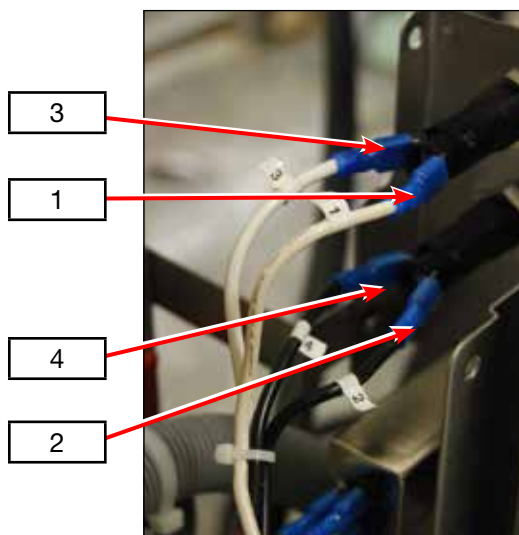

Figure 38a



Figure 38b

9.7 Removing and reinstalling the AC power inlet / EMI Filter

1. Turn unit off and disconnect power and remove top and rear panels.
2. Disconnect wiring from back of EMI Filter.
3. Remove mounting screws to release from bracket.

To replace:

1. Place EMI Filter into position in correct orientation. (Figure 38b)
2. Reconnect wiring. (Figure 39)

EMI filter – part # 01-110505S

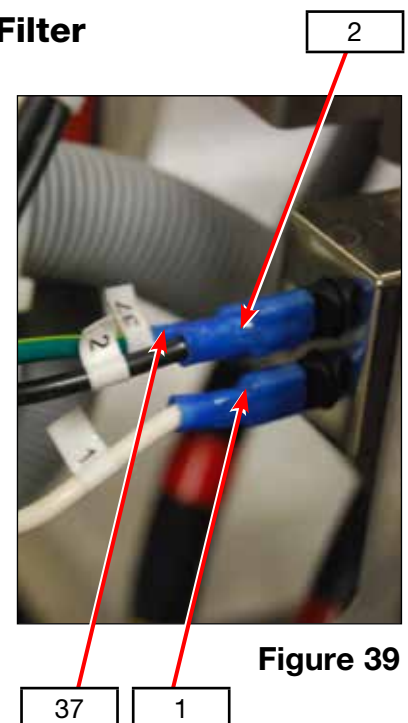

Figure 39

10. Spare Parts & Accessories

This spare part list was last updated on the date of the release of the unit.
To see an updated spare part list, please refer to my.scican.com.

01-113830S	AirBreak, L110w G4
01-113831S	Breather Check Valve, L110w/M2 G4
01-111408S	Chamber Level Switch, L110w/M2/G4
01-111409S	Chamber Pressure Switch, L110w/M2/G4
01-111465S	Circulation Pump Hydrim L110w/G4
01-111898S	Coupling Kit Circular Press. Pipe, K
01-111466S	Cover Left Side Hydrim L110w/M2/G4
01-111467S	Cover Rear Hydrim L110w/M2 G4
01-111468S	Cover Right Side Hydrim L110w/M2/G4
01-111469S	Cover Top Hydrim L110w/M2/G4
01-113833S	Decal Hydrim L110w G4
01-111670S	Detergent Coiled Tubing and Cap, K
01-113835S	Door, Chemical Hydrim L110w/M2 G4
01-113836S	Door Wash Chamber Hydrim L110w/M2 G4
01-111783S	Door Latch Assembly, L110w/M2/G4
01-112080S	Door Latch Cord Assy L110w/M2/G4
01-113837S	Dosing Pump L110w/M2 G4
01-111412S	Drain Pump, Hydrim L110w/M2/G4
01-109142S	Dryer Assy Hydrim C51w/L110w/G4
01-109144S	Dryer Fitting, J/L110w/G4
01-109143S	Dryer tubing, J/L110w/G4
01-112730S	Dual Spring Replace, Door, L110W/M2/G4
01-113838S	Extension Low Spray Arm L110w/M2 G4
01-112593S	Foam Kickplate, L110/M2
01-112545S	Fuse Holder, Qty2, Bravo/Hydrims
01-113839S	Water Heater Hydrim L110w/M2 G4
01-113840S	Hinge Left, Hydrim L110w/M2 G4
01-113841S	Hinge Right, Hydrim L110w/M2 G4
01-103472S	Fuses 15 A (2 pcs)
01-108305S	Hydrim Water Test Kit,J/K
01-107788S	Inlet Hose N.A. C61/L110w/M2/G4
01-111476S	Kickplate Front, Hydrim L110/M2/G4
01-111477S	Kickplate Rear, Hydrim L110w/M2/G4
01-109617S	Label Door Warning Hydrim SparPrt
01-112438S	Lower Basket Rail L110/M2 Kit
01-113843S	Course Filter, Hydrim L110w/M2 G4
01-113844S	Fine Filter, Hydrim L110w/M2 G4
01-113846S	Operator Manual Hydrim L110w G4
01-111667S	Packaging Hydrim L110w/G4

10. Spare Parts & Accessories

01-112024S	Rocker Switch Spare Kit, L110W/M2
01-112594S	Salt, Water Softener
01-111484S	Screw, Back Cover & Service Door, K
01-111485S	Screw, Kickplate Hydrim L110w/M2/G4
01-111483S	Screw, Top Cover Hydrim L110/M2/G4
01-113848S	Trolley, Lower Hydrim L110w G4
01-113850S	Trolley, Upper Hydrim L110w/M2 G4
01-113851S	Tubing Drain Hydrim L110w G4
01-109790S	Upper Spray Arm Hydrim
01-111495S	Wash Arm Middle L110w/M2/G4
01-113854S	Cable, Ethernet, L110w/M2 G4
01-113260S	Cable, RS232, C61/L110/M2 G4
01-113310S	IO PCB, C61/L110w/M2 G4
01-113856S	LCD Assembly, L110w/M2 G4
01-110505S	EMI Filter 20A/250V
01-110281S	Power Cord N.A. 15A/250V
01-113266S	Power Supply 5V/24V, C61/L110w/M2 G4
01-113682S	Speaker Assy, C61/L110w/M2 G4
01-113271S	Single Temp. Sensor, C61w/L110w G4
01-113331S	Valve, 1in-2out, C61/L110w/M2 G4
01-113330S	Valve, 1in-1out, C61/L110w/M2 G4
01-113665S	Colour LCD Controller, L110W
96-113788	Service Manual Hydrim L110w G4
01-113790S	Main Chamber Seal L110w/M2 G4
01-113789S	Lower Door Seal L110w/M2 G4
01-112398S	Cable, USB, Statim/HydrimL/M G4
01-113857S	Water Softener, L110w/M2/G4
01-113858S	Dosing Reservoir w/Switch L/M G4
01-113859S	Dosing Reservoir w/Plug L/M G4
01-113860S	Dosing Valve, L110w/M2 G4
01-113864S	Inlet hose EU Straight L110w/M2 G4
01-113866S	Check Valve 3/8" C61/L110w/M2/G4
01-113867S	Check Valve 1" L110w/M2/G4
01-113868S	Cable, Communication L110w/M2 G4
01-113654S	L110w/M2/G4 D-Strip Door Seal Spare

10. Spare Parts & Accessories

This accessory part list was last updated on the date of the release of the unit.
To see an updated spare part list, please refer to my.scican.com.

01-109965S	4XL Cassette Rack, 1/1, HydrimL/M2
01-109963S	5 Cassette Rack, 1/1, HydrimL/M2
01-109964S	5 Cassette Rack, 1/1, HydrimL/M2
01-111598	Basket, full size HydrimL110W/M2,K
01-109967S	Basket, Hygiene, 1/4, HydrimL/M2
01-109966S	Basket with lid, 1/4, HydrimL/M2
01-110409S	Hinged Instrument Rack, S
01-107240	Kit 2000 Basket, J
01-107241	Kit 5000 Basket, J
01-108232	Kit Basket Long, K
01-108294	Kit Basket with Hinged Lid,K
01-108371	Kit Lower Rack 4XL Cassettes, K
01-108370	Kit Upper Rack 3XL Cassettes, K
01-110412S	Tray Rack, L110/M2, S

11. Appendix A

HYDR/M L110w G4 Electrical Schematic

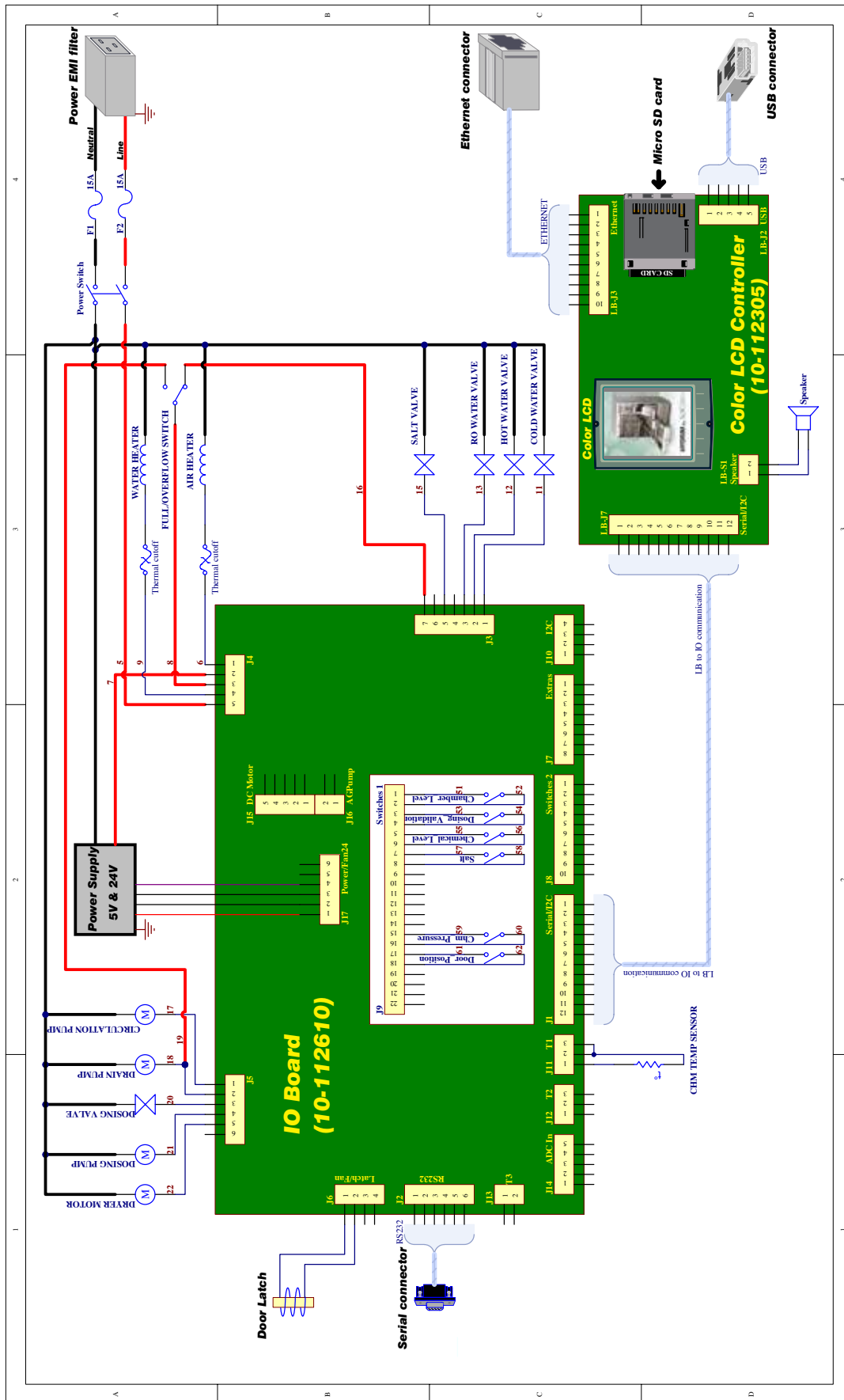

11. Appendix B

HYDR/M L110w G4 Flow Diagram

